

# 2'-6" x 4'-0" LADWP PARKWAY DUCTED PULL BOX x 3'-0" DEEP

**NOTES:**

- PULL BOX DESIGNED IN ACCORDANCE WITH AASHTO H-20-44 TRAFFIC BRIDGE LOADING USING 5,500 PSI [37-92MPa] COMPRESSIVE STRENGTH CONCRETE AND 60,000 PSI [413.2MPa] YIELD STRENGTH ASTM A-706 STEEL REINFORCING PER CALC. #51639.
- COVER DESIGNED FOR PARKWAY LOADING @ 300 PSF PER CALC. #31661.
- PULL BOX TO BE PLACED ON A MIN 6" BASE OF CRUSHER RUN FOR EASE OF INSTALLATION AND EVEN LOAD DISTRIBUTION.
- CONCRETE MIX USED IN POURING THIS PRODUCT SHALL USE FLY-ASH AS AN ADMIXTURE.
- EACH CONCRETE SECTION SHALL BE MARKED ON THE INSIDE & OUTSIDE WITH "JENSEN PRECAST"™, THE DESIGNATION "DWP/FA.", AND THE DATE OF POUR.
- EACH CONCRETE SECTION SHALL HAVE CAST-IN ON THE INSIDE "JENSEN"™ THE YEAR, AND THE DESIGNATION "FA."

**ORDERING INFORMATION:**

K3048-DP36-12P FOR ASSEMBLY AS SHOWN.  
TOTAL WEIGHT OF ASSEMBLY IS 2,579 Lbs.

**GENERAL NOTES:**

1. Minimum soil bearing capacity is hereby assumed to be 2000 PSF unless otherwise documented by a geotechnical report that shall be provided to Jensen Precast by the end user. Jensen Precast shall not be held responsible for the soil bearing capacity.
2. Installation of Manholes, Vaults, Handholes, Meter Boxes etc. will be as per Jensen installation procedures.
3. Structural modification to the Jensen line of products is not permitted without prior written approval from Jensen Engineering Department.
4. Do not scale the drawings. Verify all dimensions including rough openings, if any discrepancies are found, notify the Jensen Engineer immediately.
5. The Jensen Engineer will interpret the intent of the drawings in case of possible conflict or discrepancy.
6. Permissible Variations: Dimensional Tolerances – The length, width, height, or dia. measurements on the structure when measured on the inside surfaces shall not deviate from design dimensions by more than the following:  
Dimensions: Tolerance:  
0 to 5 Feet 1/4"  
5 to 10 Feet 3/8"  
10 to 20 Feet as agreed upon between the supplier and purchaser.  
Squares/Tolerance: The inside of the precast concrete component shall be square as determined by diagonal measurements. The difference between such measurements shall not exceed the following:  
Measured Length: Allowable Difference  
0 to 10 Feet 1/2"  
10 to 20 Feet 3/4"  
20 Feet and over as agreed upon between the supplier and purchaser.
- 7.

1. PB3048D-B30-12, 30" BOTTOM SECTION. WT. 2,010 Lbs.
2. PB3048-T6-12, 6" TOP SECTION. W/ (F3048-PB-ANG) GALV. CAST IN ANGLE FRAME. WT. 331 Lbs.
3. ONE PIECE PARKWAY POLYMER CONCRETE COVER. W/ (6) 1/2" x 13" x 2 1/2" SLOTTED S.S. HEX HEAD BOLTS. (2) 1" DIA. BLIND PICKS, HOLES. MARK "LADWP-E" WT. 236 Lbs.
4. 6" x 7" DIA. SUMP x 3" DEEP. LOCATE AS FOLLOWS: BOTTOM SECTION (1) CORE MTD.
5. 14" x 14" DUCTED K.O. x 14" DEEP. DRAFT AS FOLLOWS: T=5" S1=S2=5" B=0". LOCATE AS FOLLOWS: BOTTOM SECTION (2) CORE MTD.
- 6" x 16" K.O. x 3" DEEP. DRAFTS AS FOLLOWS: T=2" S1=S2=2" B=0". LOCATE AS FOLLOWS: BOTTOM SECTION (4) SHELL MTD.
- 7/8" DIA. x 9" GALV. VERTICAL PULL IRON. LOCATE AS FOLLOWS: BOTTOM SECTION (2) CORE MTD.
8. 1" DIA. BLIND GROUND ROD HOLE. LOCATE AS FOLLOWS: BOTTOM SECTION (2) CORE MTD.
9. 1/2" PLASTIC INSERT. LOCATE AS FOLLOWS: BOTTOM SECTION (8) CORE MTD.
11. 1/2" P-36-T INSERT. LOCATE AS FOLLOWS: TOP SECTION (2) CORE MTD. (2) SHELL MTD.
12. 1/2" P-35-T O.B. INSERT W/CLEAN-OUT HOLE. LOCATE AS FOLLOWS: TOP SECTION (6) FRAME MTD.

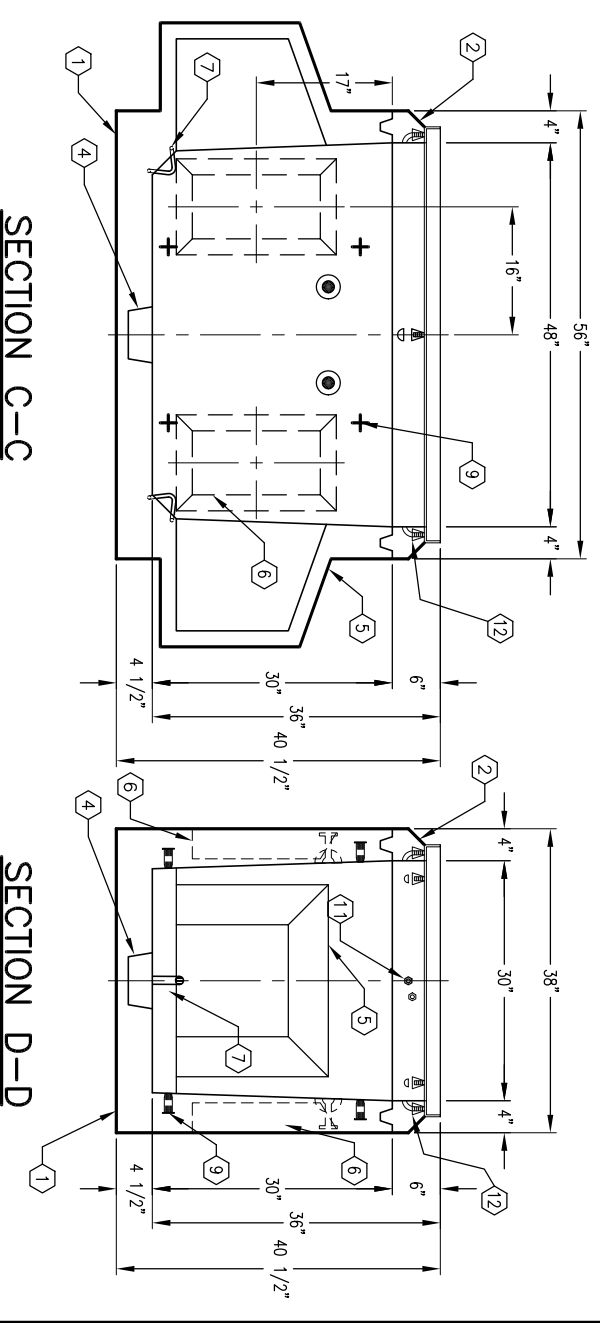
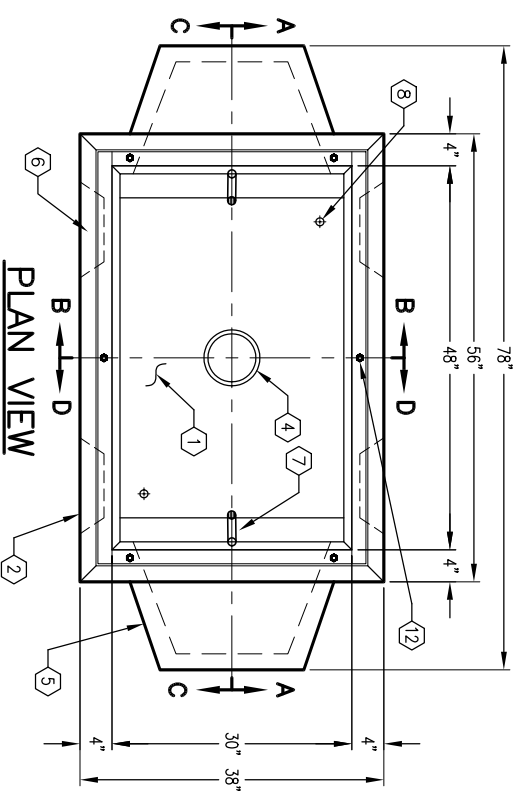
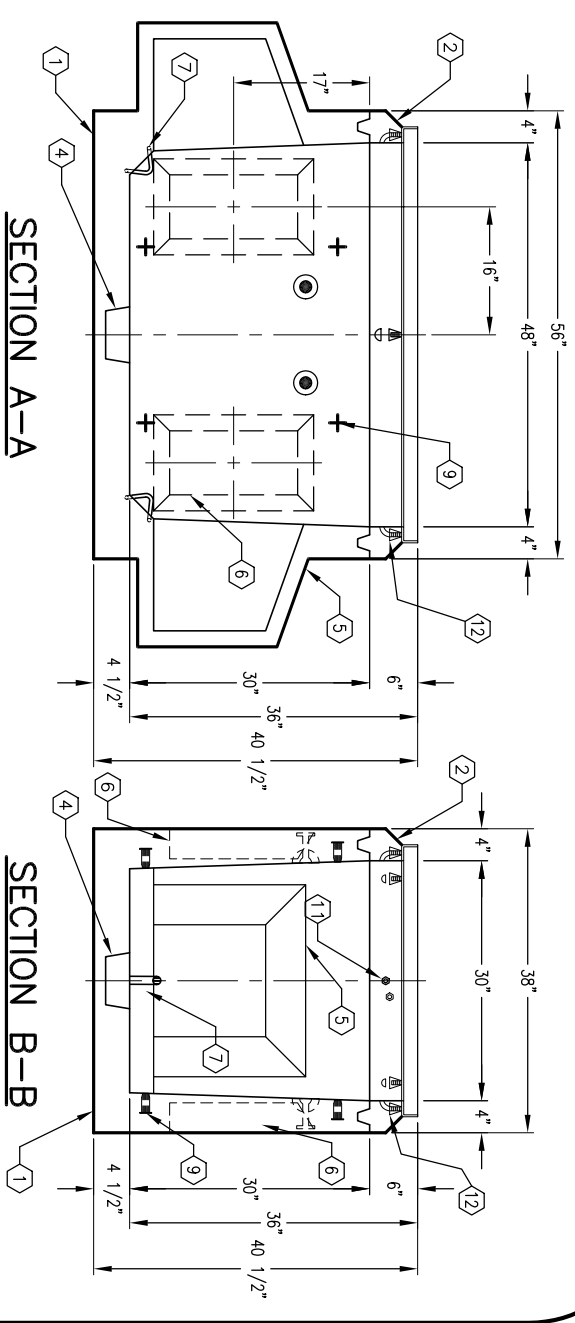
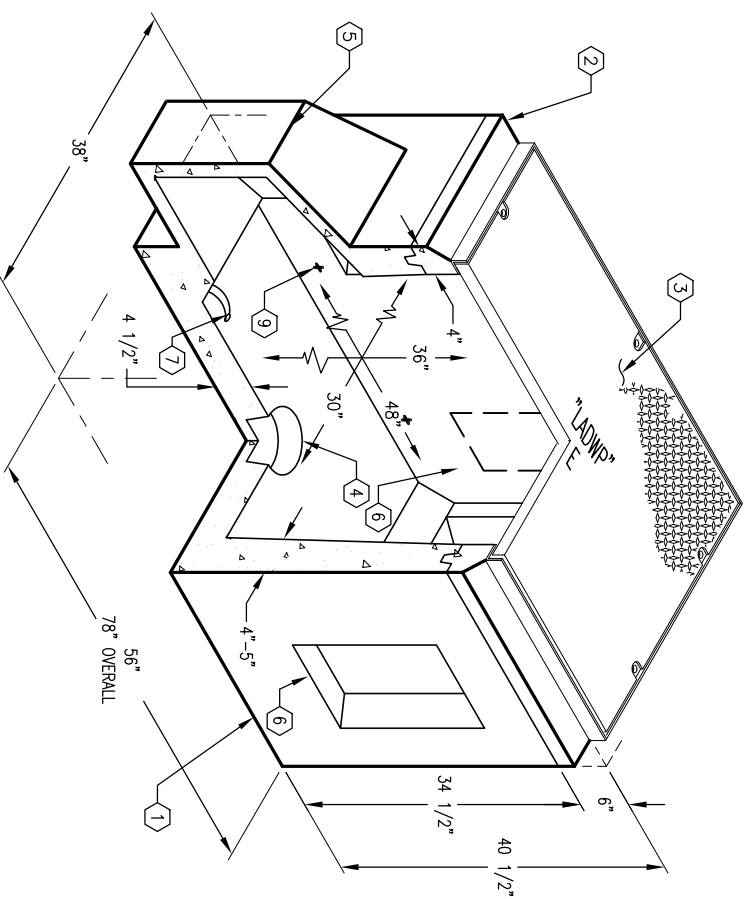

#	DATE	DESCRIPTION	BY

K3048-DP36-12P  
PER LADWP SPEC. E-491 G-2  
03-01-02



AUTOCAD REL. 14

K3048-DP36-12P  
PER LADWP SPEC. E-491 G-2  
03-01-02