

5000 GALLON GREASE INTERCEPTOR

MODEL JZ5000G

TRAFFIC RATED ACCEPTED BY UPC.

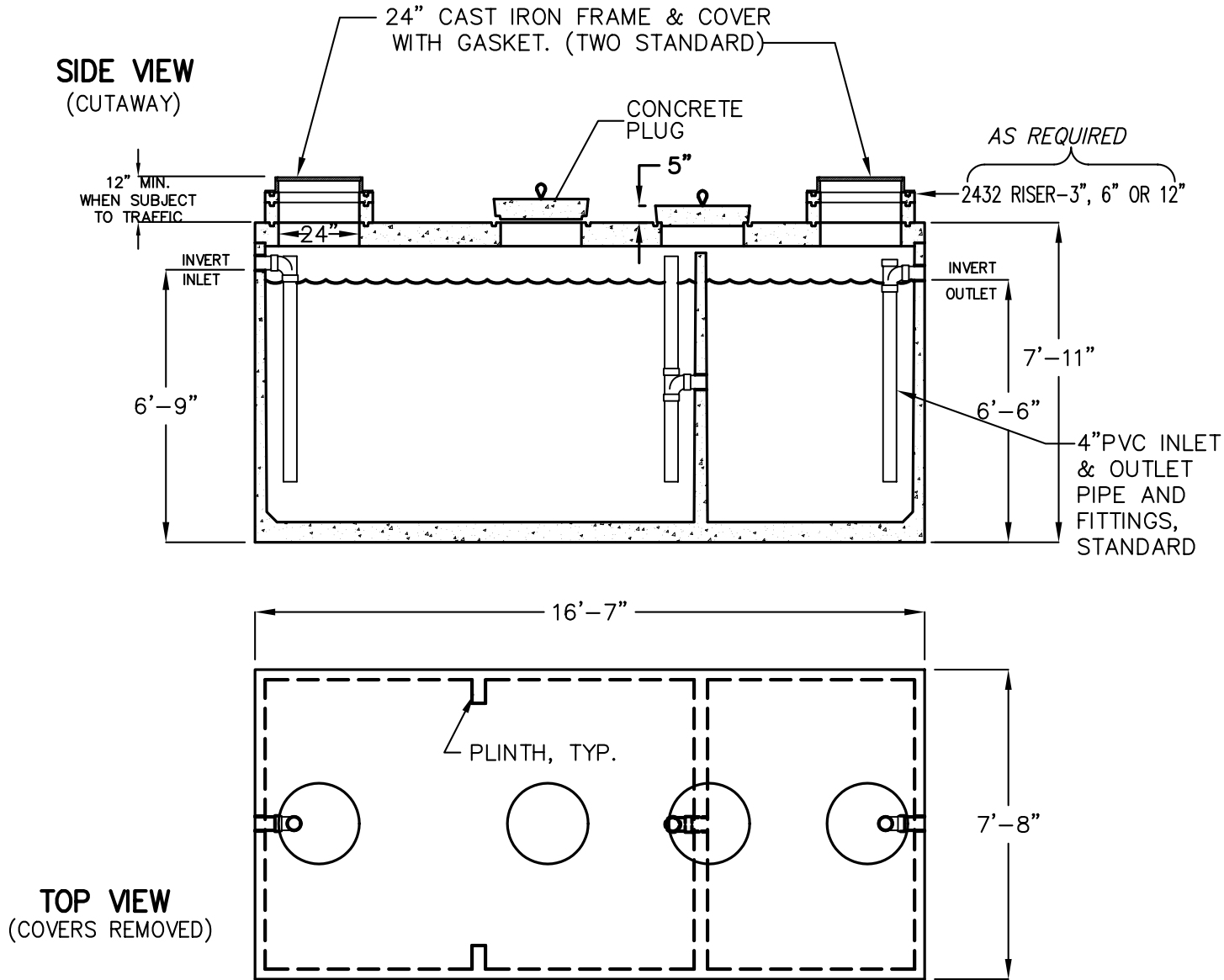

- LIQUID CAPACITY: 5,000 GALLONS.
- TANK DESIGNED FOR H-20 TRAFFIC WHEEL LOAD WITH DRY SOIL CONDITIONS (WATER TABLE BELOW TANK) EARTH COVER OVER TANK NOT TO EXCEED 4 FT.
- SUITABLE NATIVE OR SUB-BASE SHALL BE PREPARED TO HANDLE ANTICIPATED LOADS. THE EXCAVATION SHALL BE BEDDED WITH SUITABLE GRANULAR MATERIAL AND SHALL BE COMPACTED TO 90% MAXIMUM DRY DENSITY, OR TO REQUIREMENTS OF THE PROJECT GEOTECHNICAL ENGINEER.

MINIMUM EXCAVATION SIZE:
8'-8" X 17'-7" X DEPTH REQ'D.

- FOR COMPLETE DESIGN AND PRODUCT INFORMATION CONTACT JENSEN PRECAST.

THE DESIGN AND DETAIL OF THIS DRAWING ARE THE PROPERTY OF JENSEN PRECAST AND NOT TO BE USED EXCEPT IN CONNECTION WITH ITS OWN WORK. DESIGN AND INVENTION RIGHTS ARE RESERVED.