

# 8'-0" x 20'-0" ANAHEIM PARKWAY DISTRIBUTION VAULT x 9'-4" DEEP

**NOTES:**

- VAULT DESIGNED IN ACCORDANCE WITH AASHTO H-20-44 TRAFFIC BRIDGE LOADING USING 5,500 PSI COMPRESSIVE STRENGTH CONCRETE AND 60,000 PSI YIELD STRENGTH ASTM A-706 STEEL REINFORCEMENT PER CALCS. #31082.
- VAULT TO BE PLACED ON A MIN. 6" BASE OF CRUSHER RUN FOR EASE OF INSTALLATION AND EVEN LOAD DISTRIBUTION.
- INTERIOR WALLS AND CEILING SHALL BE PAINTED WITH TWO COATS WHITE PAINT. (FRAZEE #410 LATEX OR APPROVED EQUAL).
- ALL JOINTS SHALL BE GASKETED WATERTIGHT.

1. UV820-B56-162, 56" BOTTOM SECTION. WT. 45,648 Lbs.
2. UV820-T56-162P, 56" TOP SECTION. WT. 36,648 Lbs.
3. UV516-R12, 12" GRADE RING. WT. 3,300#.
4. F516-PB-BD, GALV. ANGLE FRAME W/VAULT I.D. PAD 1" x 2" x 4" LONG WELDED FLUSH WITH TOP EDGE.
5. CA516-PGBD, (6) PIECE GALV. BOLT DOWN COVER, MARKED "ELECTRIC"
6. 13" x 14" DIA. SUMP x 5" DEEP, W/GRATE RECESS TO ACCOMMODATE SUMP COVER, BOTTOM SECTION (2) CORE MTD.
7. 10" DIA. VENT K.O. x 5" DEEP, TOP SECTION (6) CORE MTD.
8. 6" DIA. TERMS, BOTTOM SECTION (32) SHELL MTD.; TOP SECTION (64) SHELL MTD.
9. 1" DIA. PVC GROUND WIRE SLEEVE, ROOF SECTION (8) CORE MTD.
10. 1" DIA. x 6" DOUBLE COIL INSERT, GALV., 10,000 LB. PULL CAPACITY, TOP SECTION (12) CORE MTD.; BOTTOM SECTION (8) CORE MTD.
11. 1/2" PLASTIC INSERTS, BOTTOM SECTION (54) CORE MTD.; TOP SECTION (54) CORE MTD.
12. 5/8" x 3 3/8" NC THREADED INSERT, 2000 LB LOAD CAPACITY, TOP SECTION (10) CORE MTD.
13. 1/2" DIA. BRONZE GROUND INSERT, GROUND TO REINFORCEMENT BARS, BOTTOM SECTION (2) CORE MTD.; TOP SECTION (2) CORE MTD.
14. 5/8" DIA. COPPER CLAD GROUND ROD, WELD TO REINFORCEMENT & PROJECT 3" MIN., BOTTOM SECTION (2) CORE MTD.

**THE FOLLOWING TO BE INSTALLED WITH VAULT:**

- a) 1 5/8" x 1 5/8" GALV. BOLT ON UNISTRUT x 48" LONG. (36 REQ'D.) W/ 1/2" DIA. ROUNDHEAD BOLTS & WAHERS (108 REQ'D.).

**ORDERING INFORMATION:**

K820-FV112-163HP FOR ASSEMBLY AS SHOWN.  
 PER CITY OF ANAHEIM SPEC. CU 1600-3H  
 TOTAL WEIGHT OF ASSEMBLY AS SHOWN IS 85,596#.

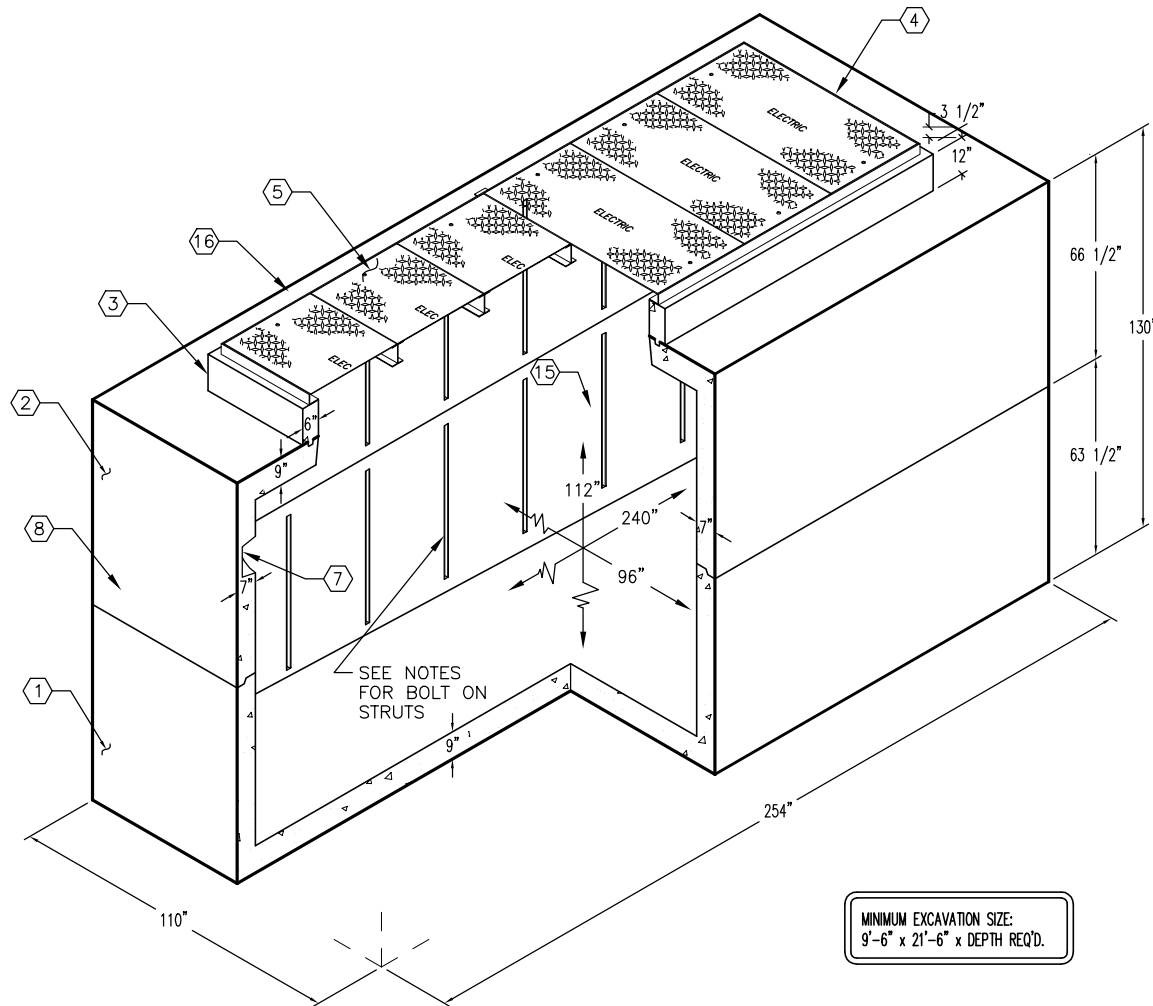

**K820-FV112-163HP**  
 PER CITY OF ANAHEIM SPEC. CU 1600-3H 03-01-02

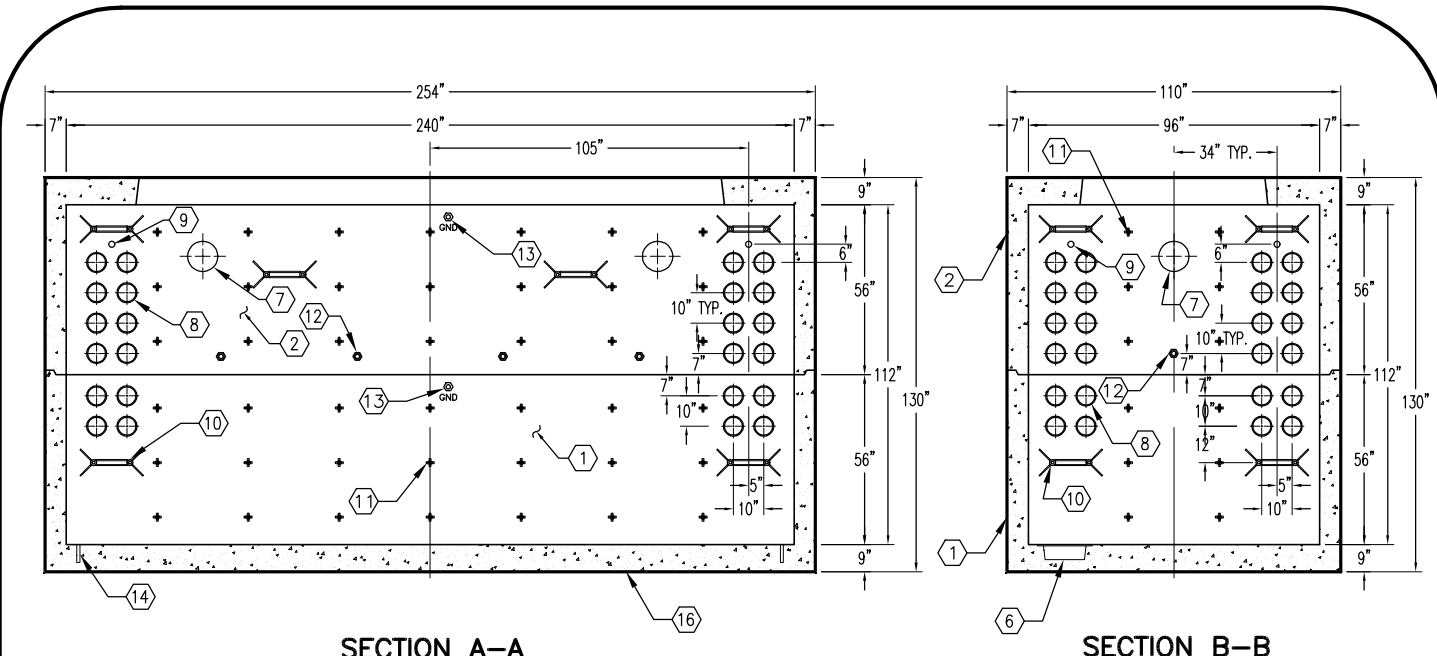

**SECTION A-A**

**SECTION B-B**

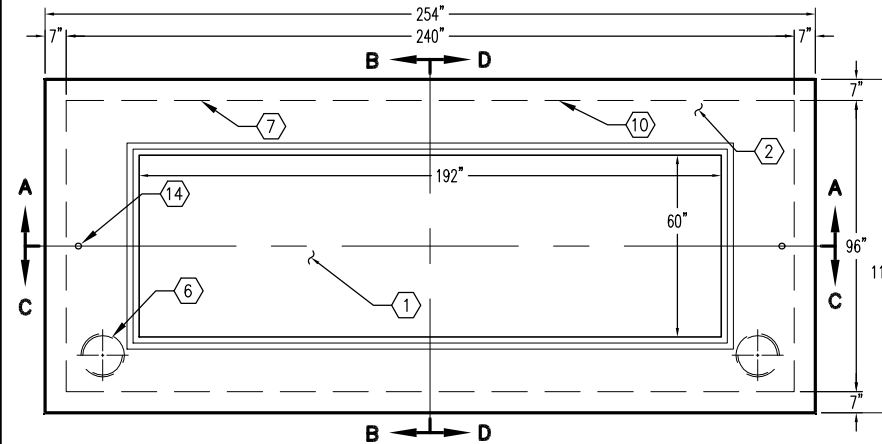

**PLAN VIEW**

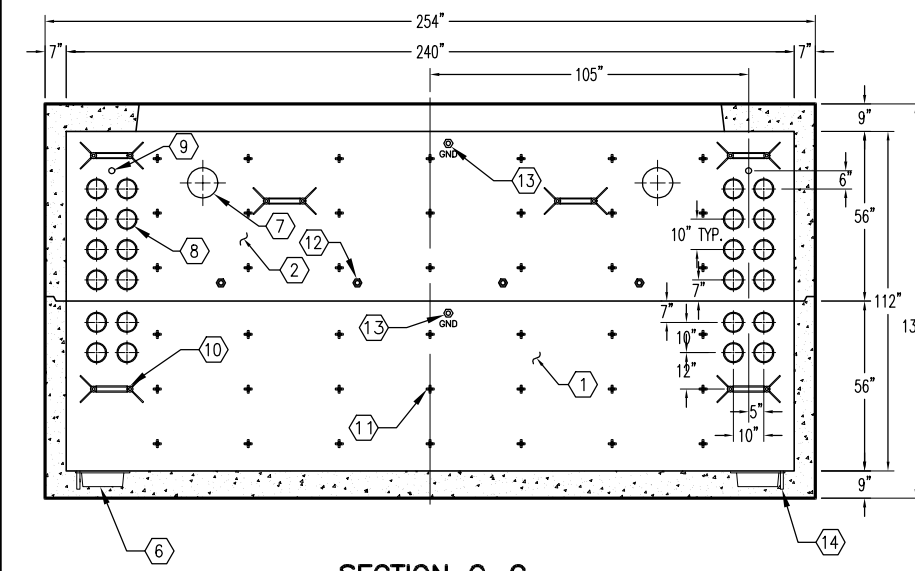

**SECTION C-C**

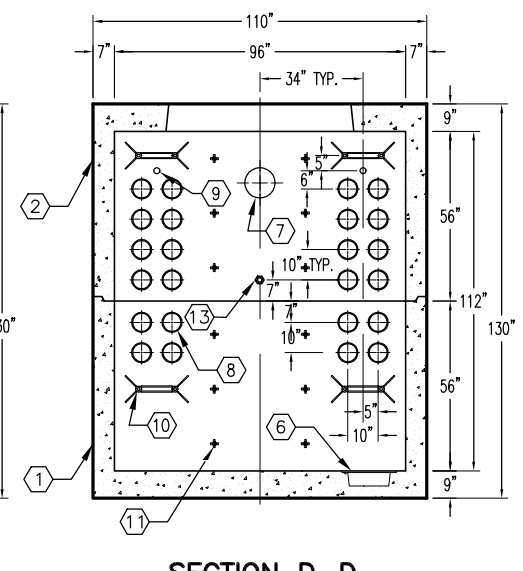

**SECTION D-D**

#	DATE	DESCRIPTION	BY

**K820-FV112-163HP**  
 PER CITY OF ANAHEIM SPEC. CU 1600-3H 03-01-02