

4'-0" x 4'-0" ANAHEIM 3-WAY PULL BOX x 48" DEEP

NOTES:

- VAULT DESIGNED IN ACCORDANCE WITH AASHTO H-20-44 TRAFFIC BRIDGE LOADING USING 5,500 PSI [37.92MPa] COMPRESSIVE STRENGTH CONCRETE AND 60,000 PSI [413.2MPa] YIELD STRENGTH ASTM A-706 STEEL REINFORCEMENT PER CALC. #30649.
- COVER DESIGNED FOR PARKWAY LOADING 300 P.S.F. OR TRAFFIC LOADING H-20.
- VAULT TO BE PLACED ON A MIN. 6" BASE OF CRUSHER RUN FOR EASE OF INSTALLATION AND EVEN LOAD DISTRIBUTION.

ORDERING INFORMATION:

PER CITY OF ANAHEIM SPEC. CU 1600-14A.
TOTAL WEIGHT OF ASSEMBLY SHOWN IS 4,674 Lbs.

1. PB44F-B30-16, 30" BOTTOM SECTION, WT. 3,061 Lbs.
2. PB44-R12, 12" EXTENSION SECTION, WT 867 Lbs.
3. PB44-T6F, 6" TOP SECTION, W/ (F44-PB-ANG) CAST-IN GALV. ANGLE FRAME, WT. 433 Lbs.
- 4A. SC3048-PGVE, ONE, PIECE PARKWAY COVER GALV., MARKED "ELECTRIC".
- 4B. SC3048-TGVE, ONE, PIECE TRAFFIC COVER GALV., MARKED "ELECTRIC".
5. 8" x 9" DIA. SUMP x 4" DEEP, LOCATE AS FOLLOWS: BOTTOM SECTION (1) CORE MTD.
6. 12" x 12" x 16" K.O. x 3 1/2" DEEP, DRAFT AS FOLLOWS: 1=S1=S2=2", B=0". LOCATE AS FOLLOWS: BOTTOM SECTION (4) SHELL MTD.
7. 1" DIA. GROUND ROD HOLE, LOCATE AS FOLLOWS: (2) CORE MTD.
8. 7/8" x 6" GALV. PULL IRON, LOCATE AS FOLLOWS: BOTTOM SECTION (2) CORE MTD.
10. @ 1/2" P-35-T OR INSERT W/CLEAN OUT HOLE, LOCATE AS FOLLOWS: TOP SECTION (8) FRAME MTD.
12. 1 5/8" x 1 5/8" x 36" LONG GALV. UNISTRUT CAST-IN (55-21-036) 4 PLACES - CORE MTD.

PARKWAY ASSEMBLY WITH STEEL B/D COVER K44-FP48-16P. LIGHT TRAFFIC ASSEMBLY WITH STEEL B/D COVER K44-FP48-16L.

1. GENERAL NOTES:
Minimum soil bearing capacity is hereby assumed to be 2000 PSF unless otherwise documented by a geotechnical report that shall be provided to Jensen Precast by the end user. Jensen Precast shall not be held responsible for the soil bearing capacity.
2. Installation of Manholes, Vaults, Handholes, Meter Boxes etc. will be as per Jensen installation procedures.
3. Structural modification to the Jensen line of products is not permitted without prior written approval from Jensen Engineering Department.
4. Do not scale the drawings, verify all dimensions including rough openings, if any discrepancies are found, notify the Jensen Engineer immediately.
5. The Jensen Engineer will interpret the intent of the drawings in case of possible conflict or discrepancy.
6. Permissible Variations:
Dimensional Tolerances - The length, width, height, or dia. measurements of the structure when measured on the inside surfaces shall not deviate from design dimensions by more than the following:
Dimensions: Tolerance:
0 to 5 Feet 1/4"
5 to 10 Feet 3/8"
10 to 20 Feet as agreed upon between the supplier and purchaser.
Squariness Tolerance:
The inside of the precast concrete component shall be square as determined by diagonal measurements. The difference between such measurements shall not exceed the following:
Measured Length: Allowable Difference
0 to 10 Feet 1/2"
10 to 20 Feet 3/4"
20 Feet and over as agreed upon between the supplier and purchaser.
- 7.

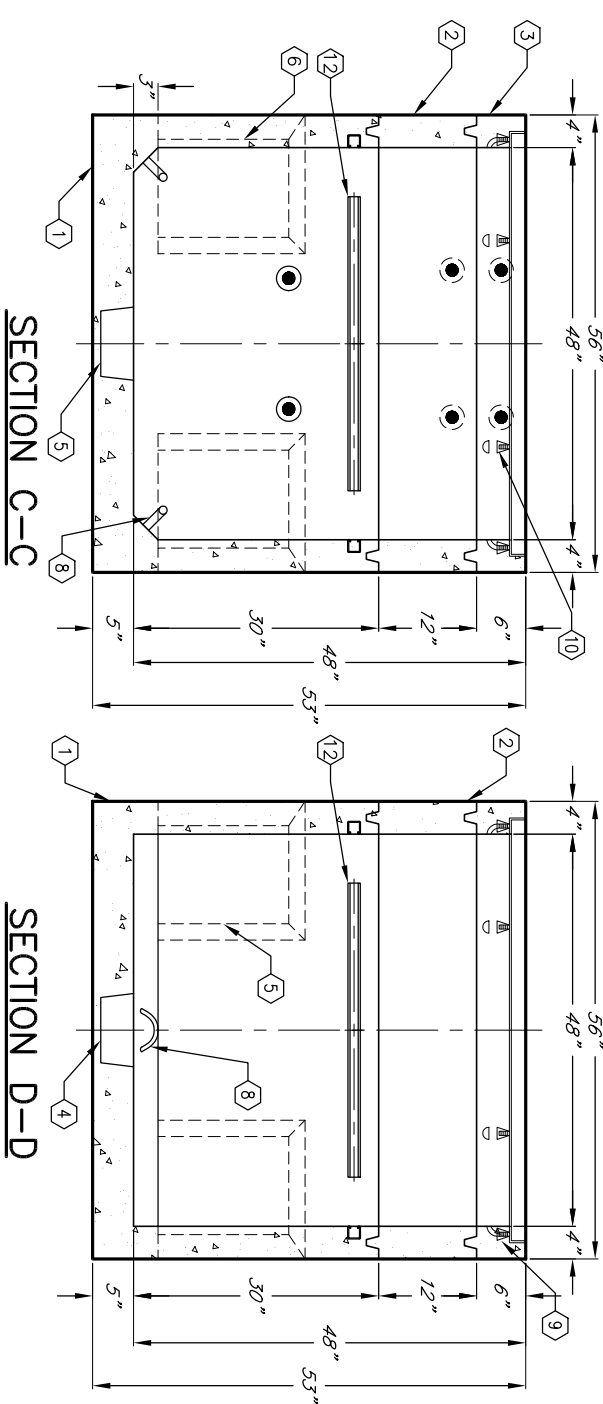
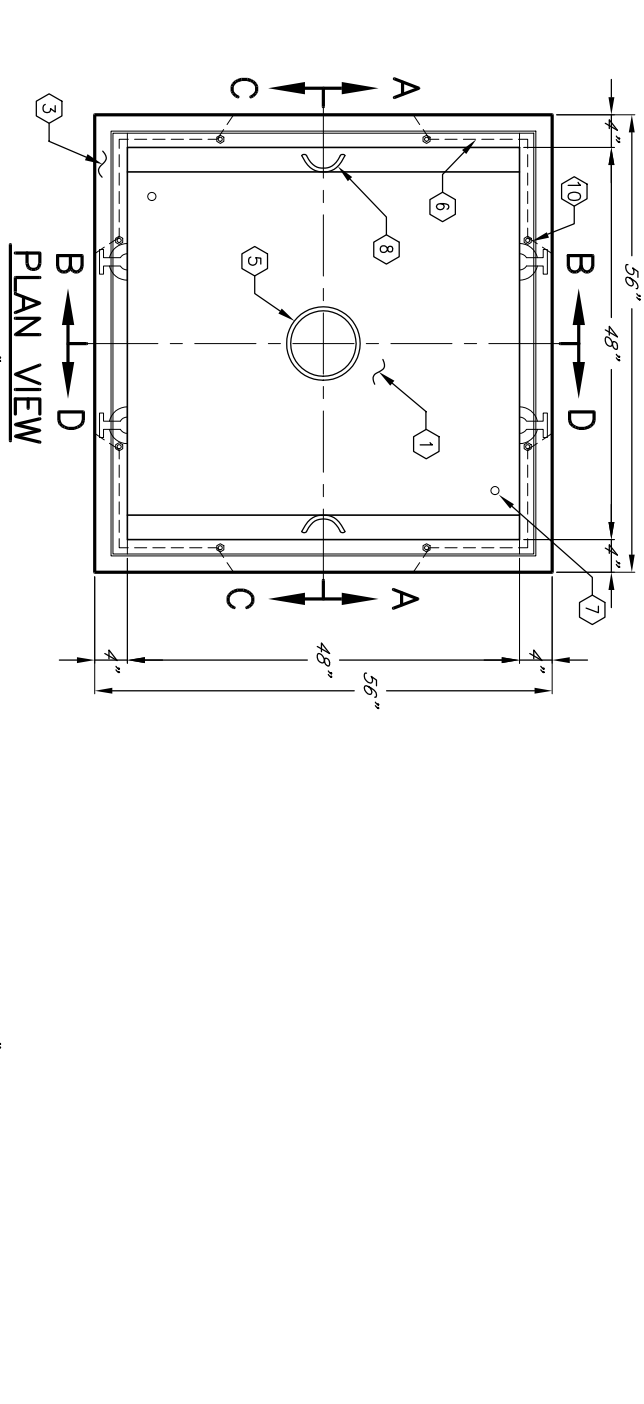
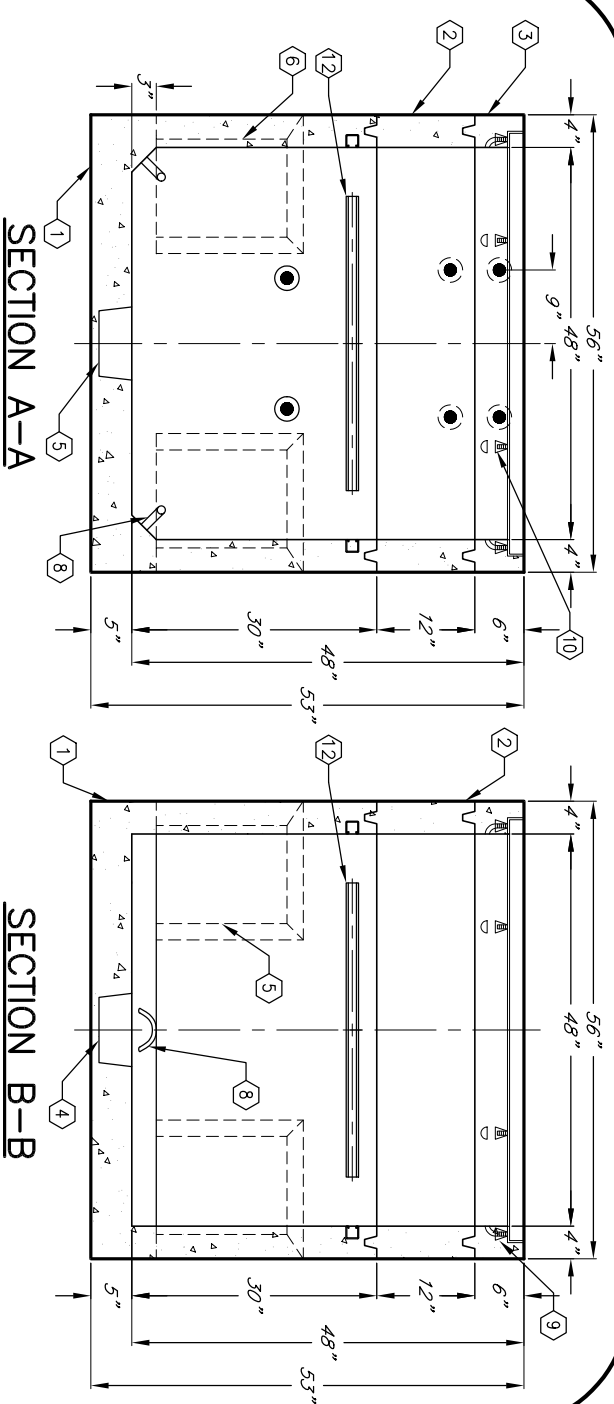
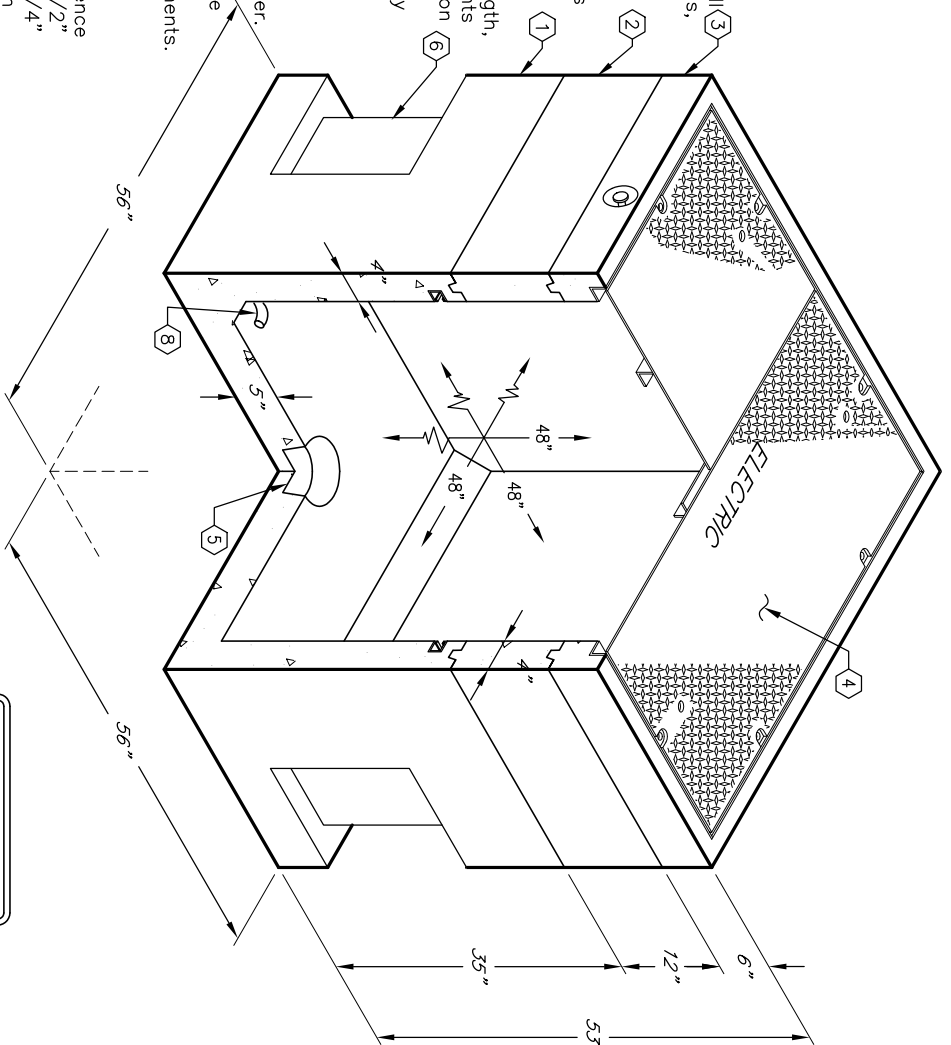

K44-FP48-16
PER CITY OF ANAHEIM SPEC. CU 1600-14A

#	DATE	DESCRIPTION	BY

K44-FP48-16
PER CITY OF ANAHEIM SPEC. CU 1600-14A