

2'-0" x 3'-0" ANAHEIM TRAFFIC FLAT WALL PULL BOX X 42" DEEP

NOTES:

- CONCRETE DESIGNED FOR H-20-44 TRAFFIC BRIDGE LOADING USING 5,500 PSI [37.92MPa] COMPRESSIVE STRENGTH CONCRETE AND 60,000 PSI [413.2MPa] YIELD STRENGTH ASTM A-706 REINFORCING STEEL PER CALCS. #31387.

- PULL BOX TO BE PLACED ON A MIN. 6" BASE OF CRUSHER RUN FOR EVEN LOAD DISTRIBUTION AND EASE OF INSTALLATION.

ORDERING INFORMATION:

K2436-FP42-16T FOR ASSEMBLY AS SHOWN.
 PER CITY OF ANAHEIM APPROVAL 01/11/01
 TOTAL WEIGHT OR ASSEMBLY AS SHOWN 1,275 LBS.

- PB2436F-B30-05, 30" BOTTOM SECTION, WT. 1,700 Lbs. WT. 1,700 lbs.
- PB2436-R6, 6" GRADE RING, WT. 300 lbs.
- PB2436-16F, 6" TOP SECTION W/ CAST-IN (F2436-PB-ANG) GALV. ANGLE FRAME, WT. 275 lbs.
- 2436 TRAFFIC ONE PIECE COVER-GALV. MARK 'ELECTRIC' #SC2436-TGV
- 6" x 7" DIA. SUMP x 4" DEEP, (1) CORE MTD.
- 20" x 20" KNOCKOUT x 3" DEEP, DRAFT AS FOLLOWS; 2" ALL SIDES TYP. BOTTOM SECTION (2) SHELL MTD.
- 8" x 16" KNOCKOUT x 3" DEEP. DRAFT AS FOLLOWS: T=2", S1=S2=2", B=2". BOTTOM SECTION (4) SHELL MTD.
- 1" DIA. BLIND THRU GROUND ROD HOLE. BOTTOM SECTION (2) CORE MTD.
- 7/8" DIA. X 9" GALV. VERTICAL PULL IRON. BOTTOM SECTION (2) CORE MTD.
- 1/2" PLASTIC INSERT BOTTOM SECTION (16) CORE MTD.
- 1/2" P-35-T INSERT W/CLEAN-OUT HOLE. TOP SECTION (2) FRAME MTD.

GENERAL NOTES:

- Minimum soil bearing capacity is hereby assumed to be 2000 PSF unless otherwise documented by a geotechnical report that shall be provided to Jensen Precast by the end user. Jensen Precast shall not be held responsible for the soil bearing capacity. Installation of Manholes, Vaults, Handholes, Meter Boxes etc. will be as per Jensen installation procedures.
- Structural modification to the Jensen line of products is not permitted without prior written approval from Jensen Engineering Department.
- Do not scale the drawings, verify all dimensions including rough openings, if any discrepancies are found, notify the Jensen Engineer immediately.
- The Jensen Engineer will interpret the intent of the drawings in case of possible conflict or discrepancy.
- Permissible Variations: Dimensional Tolerances – The length, width, height, or dia. measurements of the structure when measured on the inside surfaces shall not deviate form design dimensions by more than the following:
 Tolerance:
 0 to 5 Feet 1/4"
 5 to 10 Feet 3/8"
 10 to 20 Feet as agreed upon between the supplier and purchaser.
 Squareness Tolerance:
 he inside of the precast concrete component shall be square as determined by diagonal measurements. The difference between such measurements shall not exceed the following:
 Measured Length: Allowable Difference
 0 to 10 Feet 1/2"
 10 to 20 Feet 3/4"
 20 Feet and over as agreed upon between the supplier and purchaser.

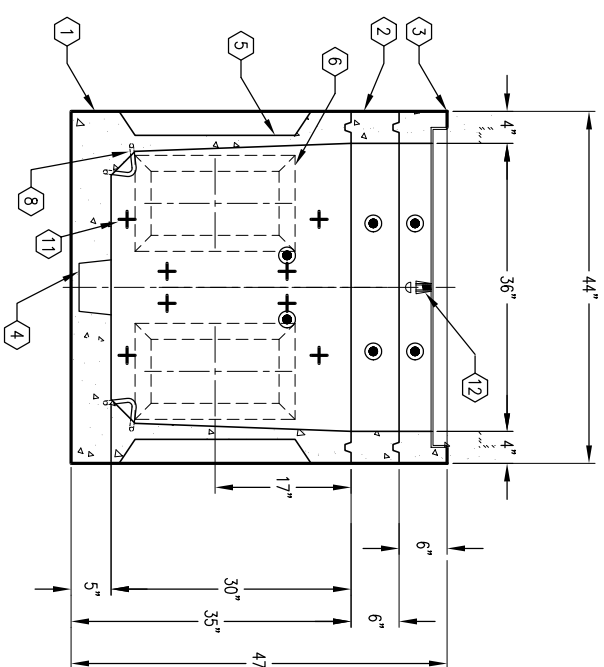
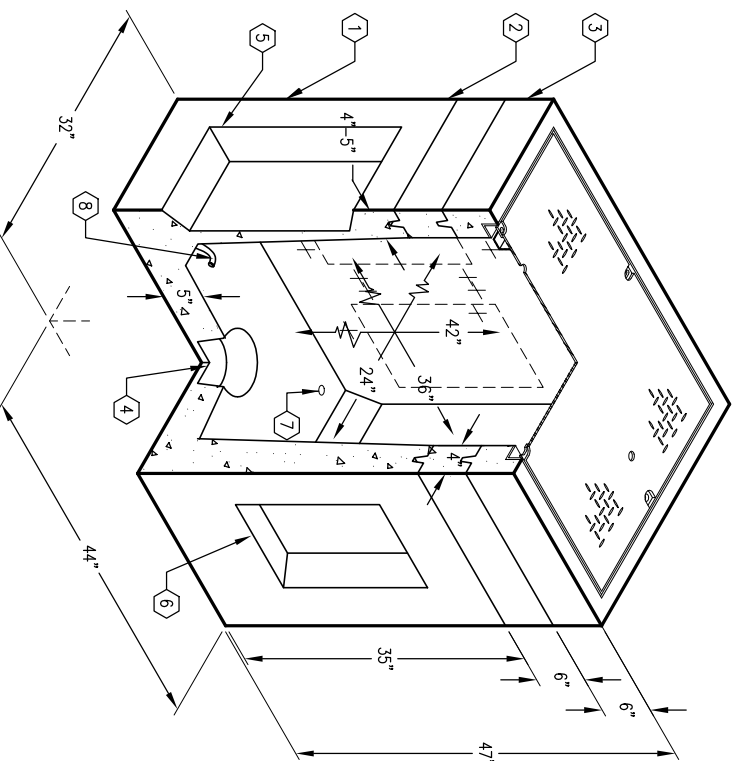

SECTION A-A

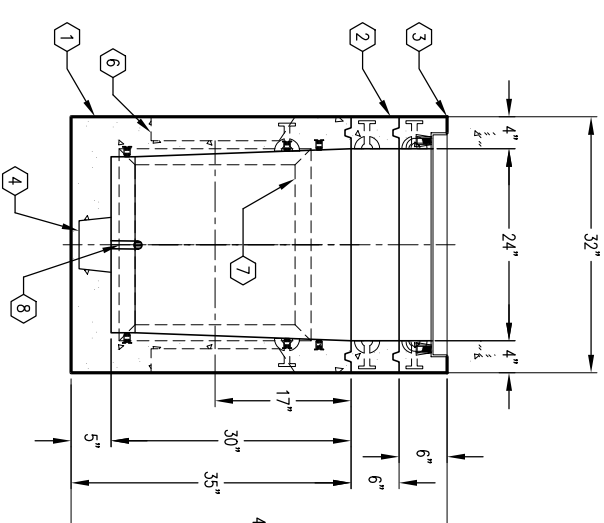

SECTION B-B

PLAN VIEW

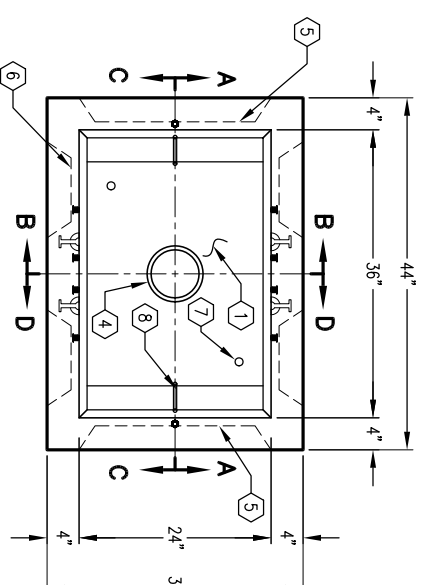

MINIMUM EXCAVATION SIZE:
 3'-2" x 4'-2" x DEPTH REQD.

K2436-FP42-16T

STANDARD ANAHEIM 03-01-02



AUTOCAD REL. 14



| # | DATE | DESCRIPTION | BY |
|---|------|-------------|----|
| | | | |

K2436-FP42-16T

STANDARD-ANAHEIM 03-01-02