

# 3'-8" x 3'-10" 50KVA TO 167KVA TRANSFORMER PAD x 6" THICK

**NOTES:**

- TRANSFORMER PAD DESIGNED FOR 300 PSF PARKWAY LOADING USING 5,500 PSI [37.92MPa] COMPRESSIVE STRENGTH CONCRETE AND 60,000 PSI [413.2MPa] YIELD STRENGTH GRADE 60 A-706 STEEL REINFORCEMENT PER CALC. #31595.
  - TRANSFORMER PAD TO BE STENCILED, "JENSEN PRECAST", AND "DATE OF POUR"
1. PD4446-T6-25, 6" THICK TRANSFORMER PAD (R-PD4446-T6-25). WT. 960 lbs.

**ORDERING INFORMATION:**

PD4446-T6-25 FOR ASSEMBLY AS SHOWN.  
 PER I.I.D. SPEC  
 TOTAL WEIGHT OF ASSEMBLY IS 638 lbs.

**GENERAL NOTES:**

1. Minimum soil bearing capacity is hereby assumed to be 2000 PSF unless otherwise documented by a geotechnical report that shall be provided to Jensen Precast by the end user. Jensen Precast shall not be held responsible for the soil bearing capacity.
2. Installation of Manholes, Vaults, Handholes, Meter Boxes etc. will be as per Jensen installation procedures.
3. Structural modification to the Jensen line of products is not permitted without prior written approval from Jensen Engineering Department.
4. Do not scale the drawings, verify all dimensions including rough openings, if any discrepancies are found, notify the Jensen Engineer immediately.
5. The Jensen Engineer will interpret the intent of the drawings in case of possible conflict or discrepancy.

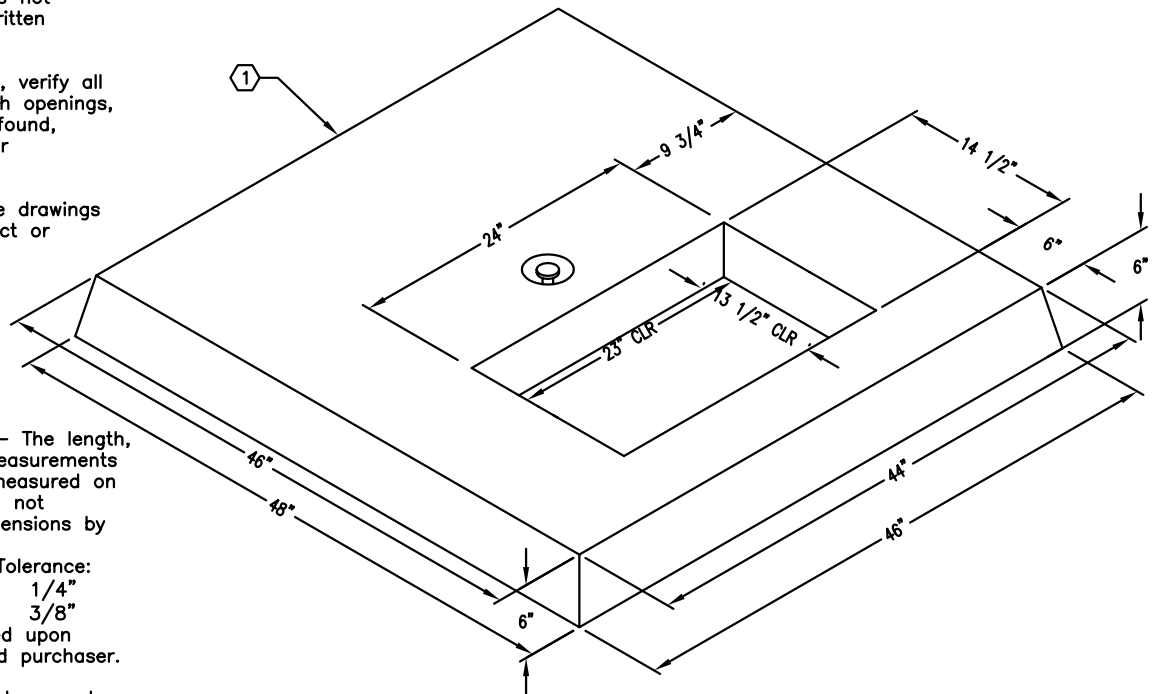

6. Permissible Variations:
  - Dimensional Tolerances - The length, width, height, or dia. measurements of the structure when measured on the inside surfaces shall not deviate from design dimensions by more than the following:

Dimensions:	Tolerance:
0 to 5 Feet	1/4"
5 to 10 Feet	3/8"
10 to 20 Feet	as agreed upon between the supplier and purchaser.
7. Squareness Tolerance:
  - The inside of the precast concrete component shall be square as determined by diagonal measurements. The difference between such measurements shall not exceed the following:

Measured Length:	Allowable Difference
0 to 10 Feet	1/2"
10 to 20 Feet	3/4"
20 Feet and over	as agreed upon between the supplier and purchaser.



#	DATE	DESCRIPTION	BY
A	09-25-02	GENERAL REVISION	YK
B	01-30-03	REMOVE UNISTRUT	DRG