

6'-0" x 12'-0" FLAT WALL MANHOLE x 7' DEEP

MATERIAL LIST- K612-FM84-11

ITEM	PART NO.	DESCRIPTION	CAGE NO. / LOCATE	WEIGHT/ MOUNT
1	UV612-B42-39	42" BOTTOM SECTION - WITH 6" TERMS	CG-612-B42-11(9)	16,800 lbs
2	UV612-T42-11M	42" TOP SECTION - WITH 5" TERMS	CG-612-T42-11M(10)	16,052 lbs
3	KNOCK OUT	13" x 14" DIA. SUMP x 3" DEEP w/RECESS	BOTTOM SECTION	(1) CORE
4a	55-30-52	5" DIA. CONTERMS	ROOF SECTION	(16) SHELL
4B	55-30-61	6" DIA. CONTERMS	BOTTOM SECTION	(24) SHELL
5		18" x 18" UNREINFORCED PANEL	ROOF SECTION	(4) CORE
6	55-35-06	7/8" DIA. x 6" GALV. VERTICAL PULL IRON	BOTTOM SECTION	(4) CORE
			TOP SECTION	(4) CORE
7	55-10-425	1/2" THREADED BRONZE GROUND INSERT WELD TO REBAR "GRD" SHOULD BE STENCILED IN RED LETTERS	BOTTOM SECTION	(2) CORE
			ROOF SECTION	(4) CORE
8	55-10-422	1/2" LOOP INSERT	ROOF SECTION	(4) CORE

NOTES:

- MANHOLE DESIGNED IN ACCORDANCE WITH AASHTO H-20-44 TRAFFIC BRIDGE LOADING USING 5,500 PSI [37.92MPa] COMPRESSIVE STRENGTH CONCRETE AND 60,000 PSI [413.2MPa] YIELD STRENGTH ASTM A-706 STEEL REINFORCEMENT PER CALCS. #31094.
- MANHOLE TO BE PLACED ON A MIN. 6" BASE OF CRUSHER RUN FOR EASE OF INSTALLATION AND EVEN LOAD DISTRIBUTION
- LIMIT OF COVER OVER ROOF SECTION IS 1'-6" TO 4'-0"

- LIMIT OF EMBEDMENT OF BOTTOM SECTION IS 10'-8" TO 13'-2"

- ALL WALLS AND CEILINGS TO BE PAINTED WITH WHITE PAINT
- STRUCTURAL DESIGN APPROVED BY LOS ANGELES COUNTY ROAD AND BRIDGE DEPARTMENT.

FOLLOWING MATERIALS TO BE SHIPPED WITH MANHOLE:

- (a) 1/2" x 6" GALVANIZED "J" BOLTS (4 REQ'D)
- (b) 7/8" x 1 3/4" CONSEAL GASKET (33 FT. REQ'D)

ORDERING INFORMATION:

K612-FM84-39 FOR ASSEMBLY AS SHOWN
PER CITY OF CORONA SPECS.
TOTAL WEIGHT OF ASSEMBLY IS 32,852 Lbs.

NOTCH DETAIL

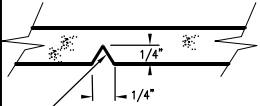

V" SHAPE NOTCH ON INSIDE WALLS
TO OUTLINE UNREINFORCED 18" x 18" PANELS

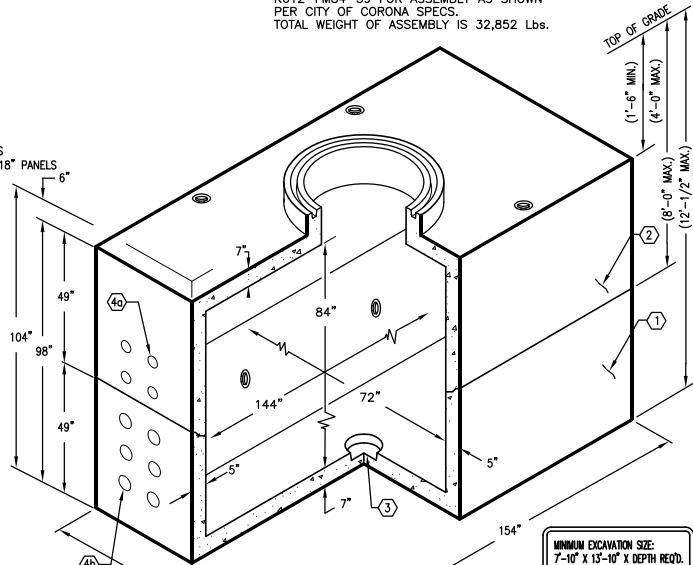

K612-FM84-39

PER CITY OF CORONA SPEC. 04-23-04

JENSEN
PRECAST

AUTOCAD REL. 14

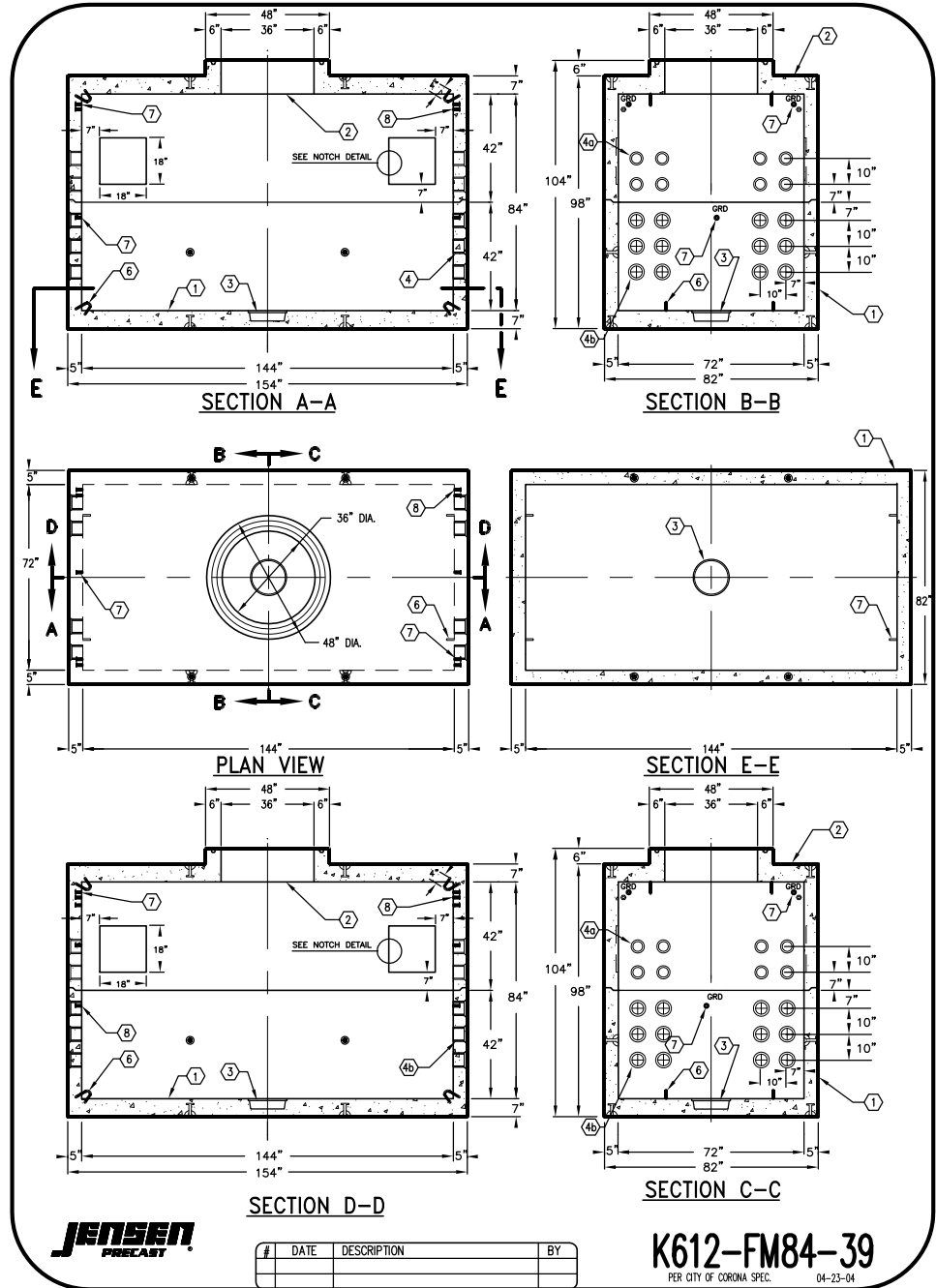

JENSEN
PRECAST

K612-FM84-39

PER CITY OF CORONA SPEC. 04-23-04

#	DATE	DESCRIPTION	BY