

6'-0" x 8'-0" ANAHEIM TRANSFORMER PAD W/4'-0" x 7'-0" PARKWAY ENCLOSURE x 3'-6" DEEP

NOTES:

- TRANSFORMER PAD AND ENCLOSURE ARE DESIGNED IN ACCORDANCE WITH AASHTO H-20-44 BRIDGE LOADING USING 5,500 PSI [37.92MPa] COMPRESSIVE STRENGTH CONCRETE AND 60,000 PSI [413.2MPa] YIELD STRENGTH ASTM A-706 STEEL REINFORCEMENT PER CALC. #30207.
 - COVER IS DESIGNED FOR PARKWAY LOADING PER CALCS. # 30448 @ 300 PSF.
 - VAULT TO BE PLACED ON A 6" BASE OF CRUSHER RUN FOR EVEN LOAD DISTRIBUTION AND EASE OF INSTALLATION.
- ORDERING INFORMATION:**
- K68-SB42-16 FOR ASSEMBLY AS SHOWN.
 APPROVED FOR CITY OF ANAHEIM SPEC. CU1600-20.
 TOTAL WEIGHT OF ASSEMBLY AS SHOWN IS 9,117 Lbs.
1. SB47-B42-11, 42" BOTTOM SECTION, WT. 6,400 Lbs.
 2. PD7296-16-16, 6" TRANSFORMER PAD, WT. 2,588 Lbs. W/ ANGLE FRAME CAST-IN (F3048-PB-ANG).
 3. SC3048-PGV-16, ONE PIECE PARKWAY GALV. STEEL COVER W/ (6) 1/2" x 1 1/4" SH.H.S. BOLTS, MARK "ELECTRIC" (2) PICK HOLES GALVANIZED FINISH, WT. 129 Lbs.
 4. 16" x 20" KNOCKOUT x 3 1/2" DEEP (5000-397). DRAFT AS FOLLOWS: T=2", S1= 3 1/2", S2=3 1/2", B=2". LOCATE AS FOLLOWS: BOTTOM SECTION (8) SHELL MTD.
 5. 1/2" P-35-T INSERT W/CLEAN-OUT HOLE. LOCATE AS FOLLOWS: TRANSFORMER PAD (6) FRAME MTD.
 6. 1" GALVANIZED COIL THREAD INSERT. LOCATE AS FOLLOWS: BOTTOM SECTION (4) CORE MTD.
 8. 1 5/8"x1 5/8" UNISTRUT 10" LONG. (2) TOP SLAB SURFACE MTD.

GENERAL NOTES:

1. Minimum soil bearing capacity is hereby assumed to be 2000 PSF unless otherwise documented by a geotechnical report that shall be provided to Jensen Precast by the end user. Jensen Precast shall not be held responsible for the soil bearing capacity.
2. Installation of Manholes, Vaults, Handholes, Meter Boxes etc. will be as per Jensen installation procedures.
3. Structural modification to the Jensen line of products is not permitted without prior written approval from Jensen Engineering Department.
4. Do not scale the drawings, verify all dimensions including rough openings, if any discrepancies are found, notify the Jensen Engineer immediately.
5. The Jensen Engineer will interpret the intent of the drawings in case of possible conflict or discrepancy.
6. Permissible Variations:
 - Dimensional Tolerances – The length, width, height, or dia. measurements of the structure when measured on the inside surfaces shall not deviate from design dimensions by more than the following:
 - Dimensions: Tolerance:
 - 0 to 5 Feet 1/4"
 - 5 to 10 Feet 3/8"
 - 10 to 20 Feet 1/2"
 - Squareness Tolerance:
 - The inside of the precast concrete component shall be square as determined by diagonal measurements. The difference between such measurements shall not exceed the following:
 - Measured Length: Allowable Difference
 - 0 to 10 Feet 1/2"
 - 10 to 20 Feet 3/4"
7. Between the supplier and purchaser.

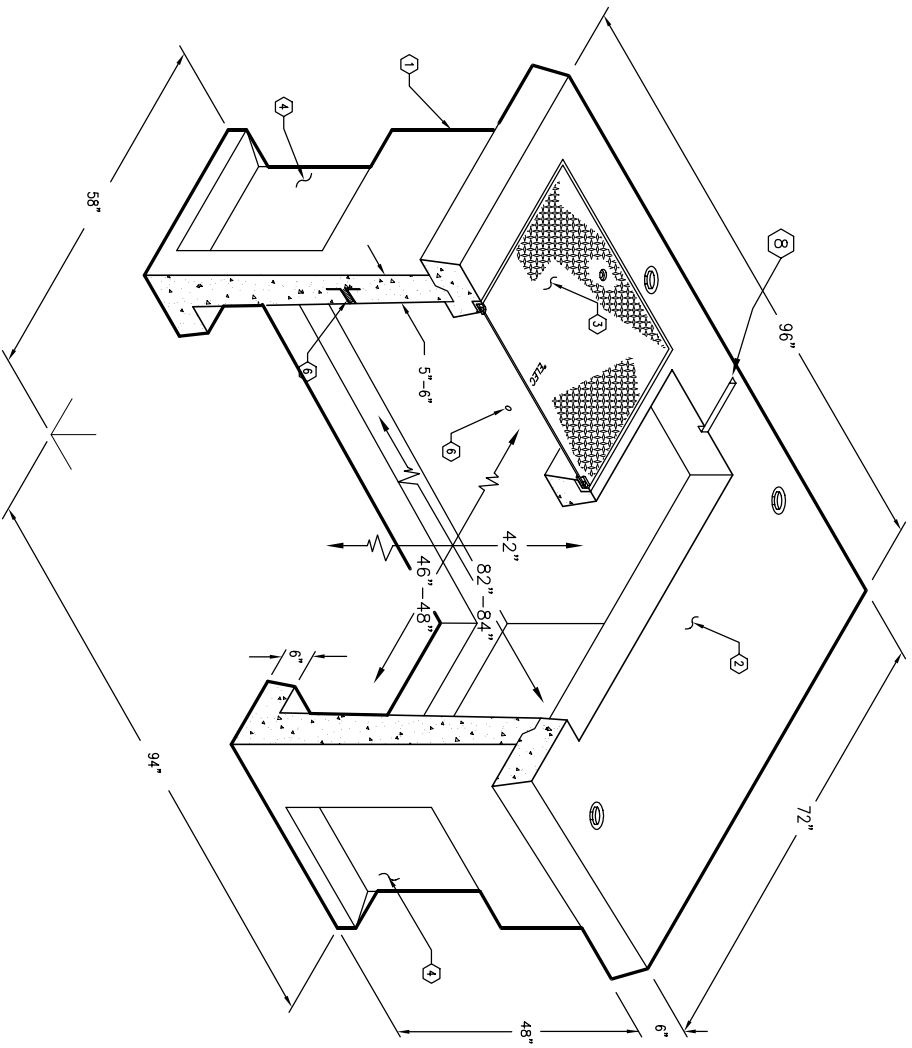

MINIMUM EXCAVATION SIZE:
 5'-8" x 8'-10" x DEPTH REQ'D.

K68-SB42-16

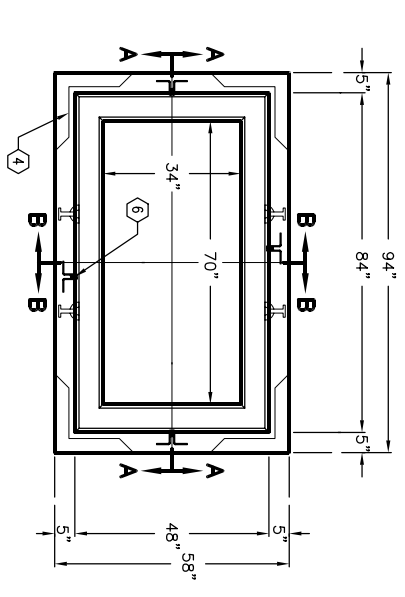

PLAN VIEW W/O TRANSFORMER PAD

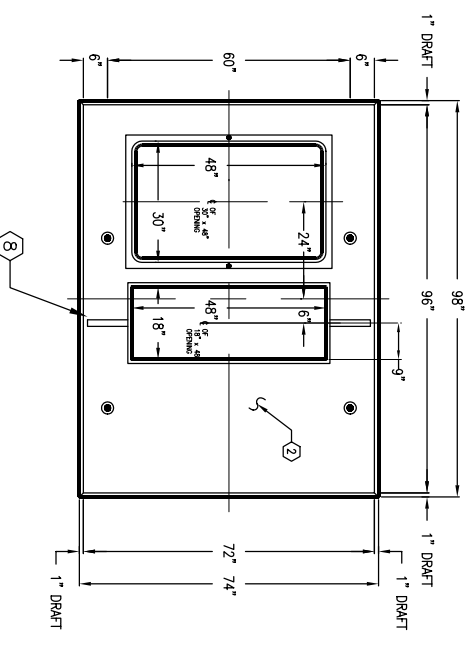

PLAN VIEW OF TRANSFORMER PAD

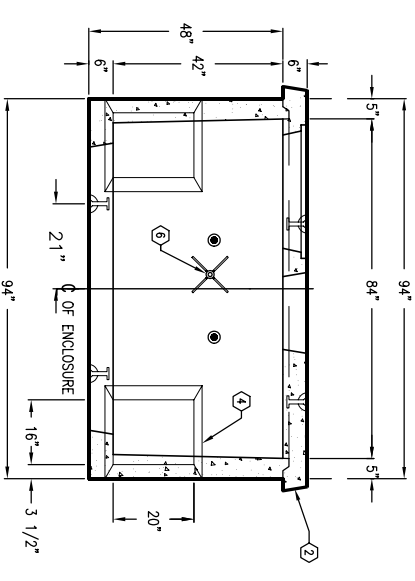

SECTION A-A

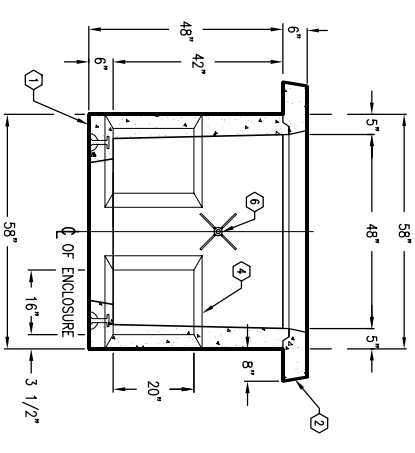

SECTION B-B

#	DATE	DESCRIPTION	BY

K68-SB42-16