

30" DIA. RIVERSIDE MANHOLE TRAFFIC COVER & NECK x 14" DEEP

NOTES:

■ CONCRETE DESIGNED IN ACCORDANCE WITH AASHTO HS 20-44 TRAFFIC BRIDGE LOADING USING 5,500 PSI COMPRESSIVE STRENGTH CONCRETE AND 60,000 PSI YIELD STRENGTH ASTM A-706 STEEL REINFORCING PER CALCS. #31637.

ORDERING INFORMATION:

K36-MN14-18T FOR ASSEMBLY AS SHOWN
 PER CITY OF RIVERSIDE UGS-053.
 TOTAL WEIGHT OF ASSEMBLY IS 1,135 lbs.

1. MN36-N12, 12" CONE/NECK SECTION. WT. 430 lbs.
2. MN36-R3, 3" RISER RING. WT. 146 lbs.
3. MN36-R6, 6" RISER RING. WT. 301 lbs.
4. MN36-R12, 12" RISER RING. WT. 602 lbs.
5. A-1106 30" DIA. CAST IRON RING. WT. 95 lbs.
6. A-1106 30" DIA. CAST IRON COVER. MARK "RIVERSIDE ELECTRIC". WT. 290 lbs.
7. 1/2" P-36-T INSERT, NECK SECTION (4) SURFACE MTD.
8. 1/2" x 5" ADJUSTING BOLT W/(2) NUTS & WASHERS EACH. (4) REQ'D.
10. 5/8" x 1 1/2" STAINLESS STEEL HEX HEAD BOLT. (4) REQ'D.

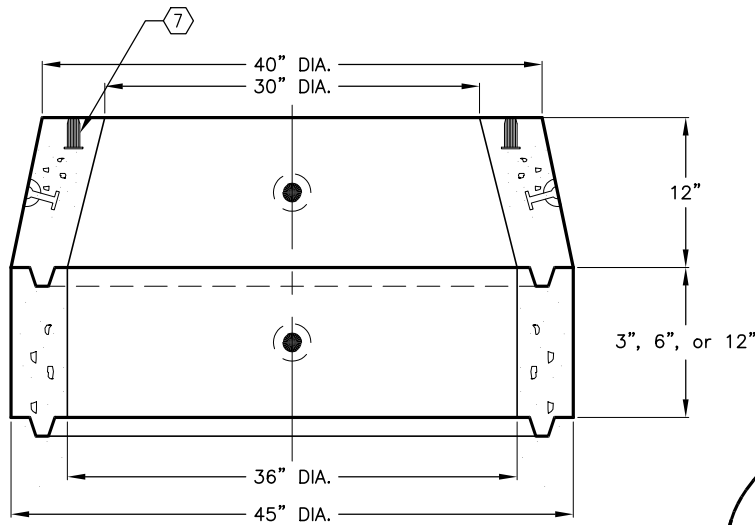

SECTION A-A

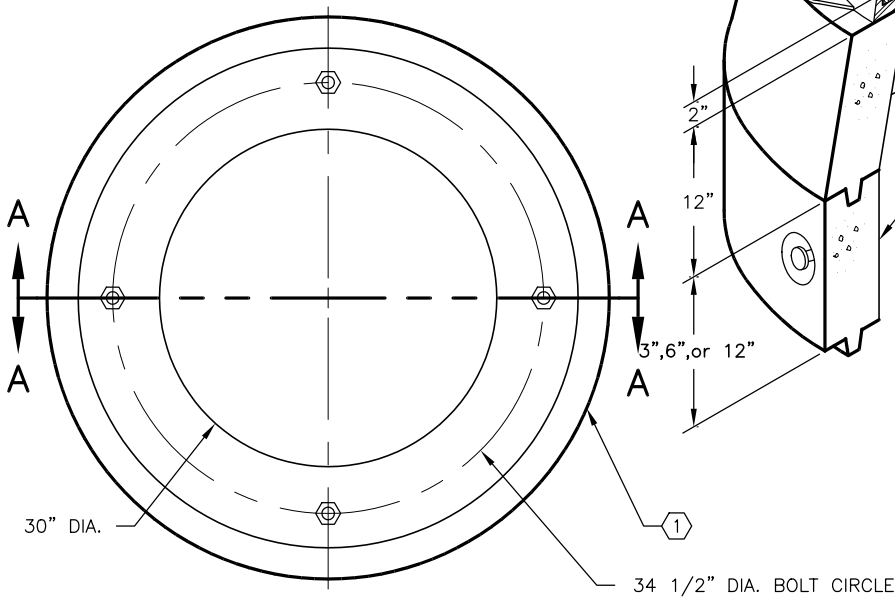
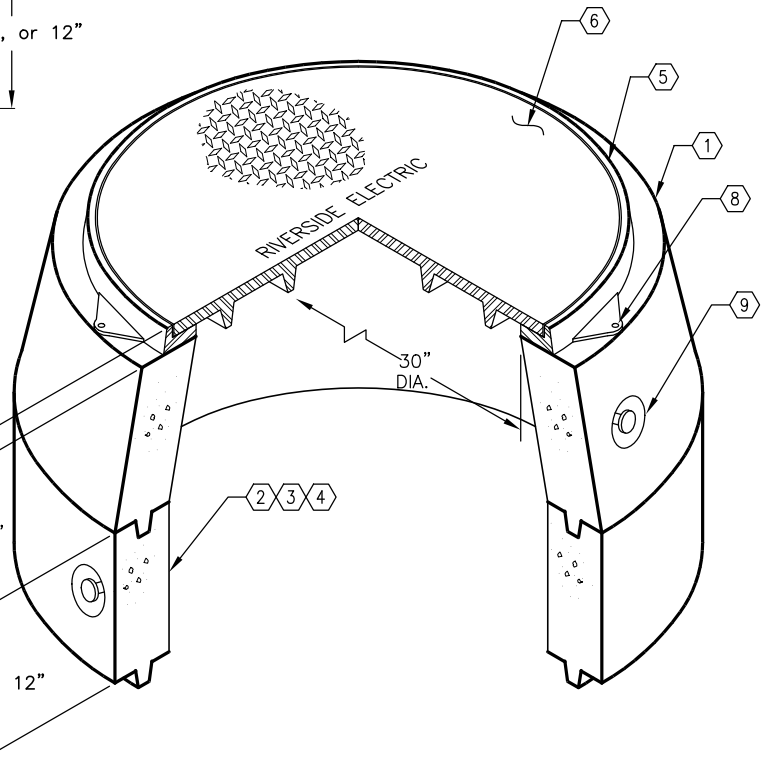

PLAN VIEW

| # | DATE | DESCRIPTION | BY |
|---|------|-------------|----|
| | | | |
| | | | |

K36-MN14-21T
 PER CITY OF RIVERSIDE UGS-053 03-01-02