

3'-0" x 5'-0" RIVERSIDE TRAFFIC INTERCEPT BOX x 4'-0" DEEP

NOTES:

□ PULL IRON BOX DESIGNED IN ACCORDANCE WITH ASHTO H-20-44 TRAFFIC BRIDGE LOADING USING 5,500 PSI COMPRESSIVE STRENGTH CONCRETE AND 60,000 PSI YIELD STRENGTH ASTM A-706 STEEL REINFORCEMENT PER CALC. #31435.

□ COVER DESIGNED FOR H-20-44 TRAFFIC LOADING FOR USE IN OFF-STREET LOCATIONS PER CALC. #31608.

ORDERING INFORMATION:
K3660-D148-21T FOR ASSEMBLY AS SHOWN.
TOTAL WEIGHT OF ASSEMBLY IS 6,541#.

1. PB3660-B7, 7" BOTTOM SECTION, WT. 2,980#.
2. PB3660D-135-05, 35" INTERCEPT SECTION, WT. 2,852#.
3. PB3660-16F, 6" TOP SECTION, W/F3660-P8-ANG GALVANIZED ANGLE FRAME CAST IN, WT. 527#.
4. SC3660-1AL, TWO PIECE BOLT DOWN TRAFFIC ALUMINIUM COVER W/(8) 1/2" x 13NC PENNHEAD S.S. BOLTS.
5. 6" DIA. X 7" DIA. SLUMP X 2" DEEP. LOCATE AS FOLLOWS: BOTTOM SECTION (1) CORE MTD.
6. 18" x 24 1/4" KNOCKOUT x 10 3/4" DRAFT AS FOLLOWS: T=1 1/2", S1=6", S2=6", B=0. LOCATE AS FOLLOWS: INTERMEDIATE SECTION (2) CORE MTD.
7. 8" x 16" KNOCKOUT x 4" DEEP. DRAFT AS FOLLOWS: INTERMEDIATE SECTION (4) SHELL MTD.
8. 1" DIA. BLIND GROUND ROD HOLE. LOCATE AS FOLLOWS: BOTTOM SECTION (2) CORE MTD.
9. 7/8" DIA. X 9" GALVANIZED PULL IRON. LOCATE AS FOLLOWS: BOTTOM SECTION (2) CORE MTD.
10. + 1/2" 1-5000 PLASTIC RACKING INSERT. LOCATE AS FOLLOWS: INTERMEDIATE SECTION (16) CORE MTD.
11. ● 1/2" P-36-T O.B. INSERT. LOCATE AS FOLLOWS: TOP SECTION (8) CORE MTD.

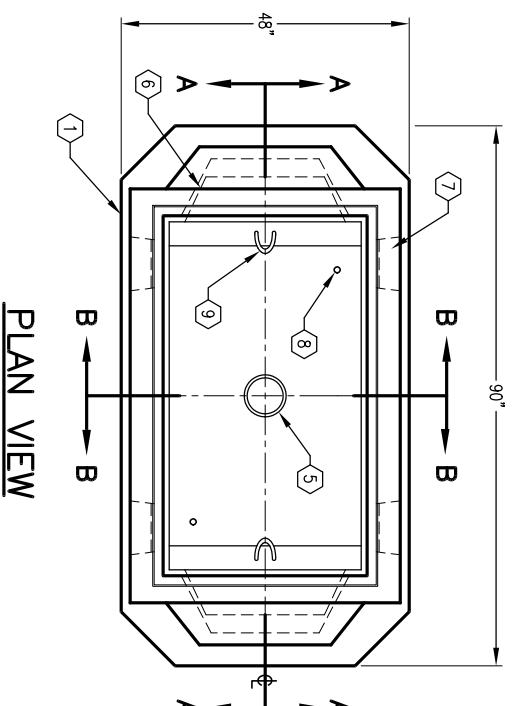
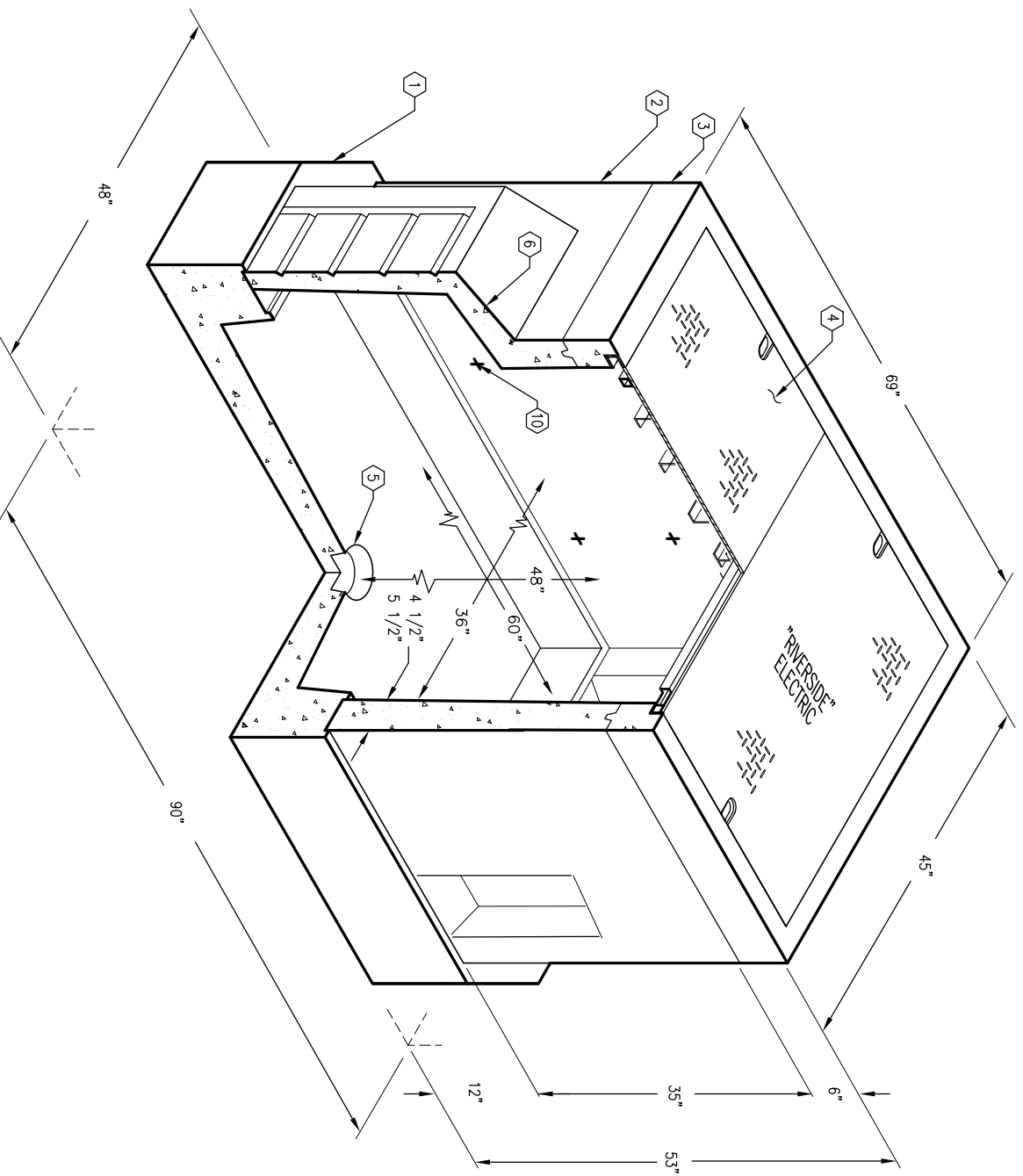

PLAN VIEW

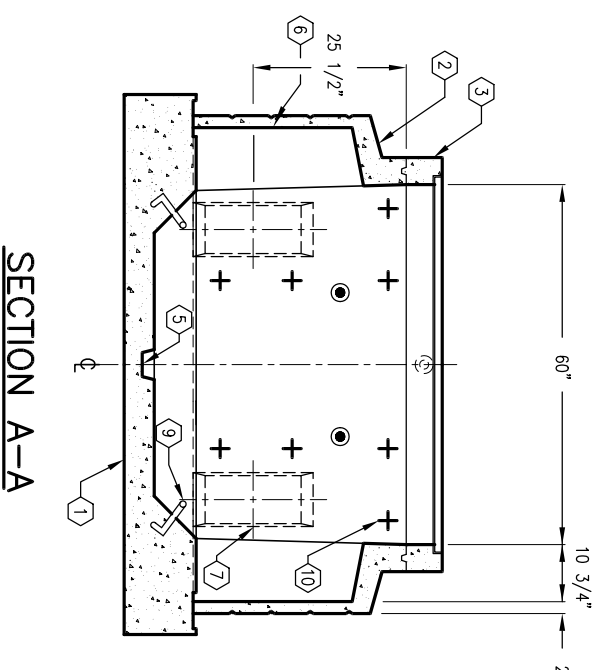

SECTION A-A

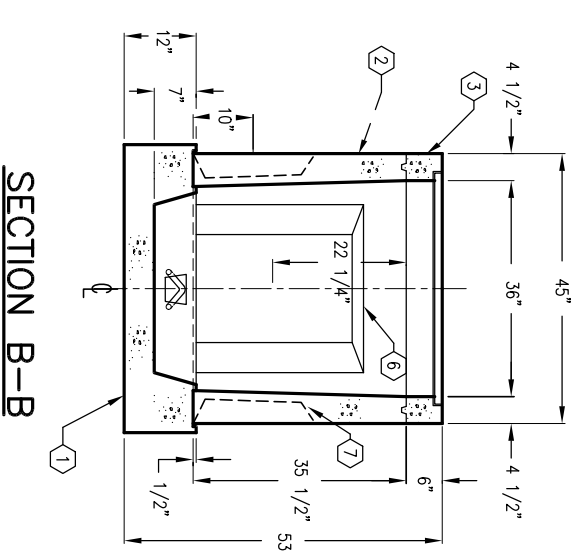

SECTION B-B

#	DATE	DESCRIPTION	BY