

3'-6" RIVERSIDE PARKWAY BURD TRANSFORMER ENCLOSURE X 6'-7" DEEP

NOTES:

CONCRETE DESIGNED IN ACCORDANCE WITH ASHTO H-20-44 TRAFFIC BRIDGE LOADING USING 5,500 PSI [37.92MPa] COMPRESSIVE STRENGTH CONCRETE AND 60,000 PSI [413.2MPa] YIELD STRENGTH ASTM A-706 STEEL REINFORCEMENT PER CALC. #31641.

TO BE PLACED ON A LEVEL MIN. 6" BASE OF CRUSHER RUN FOR EVEN LOAD DISTRIBUTION AND EASE OF INSTALLATION.

THE FOLLOWING MATERIAL TO BE SHIPPED WITH EACH VAULT:

- (a) 3/4" x 4" BOLT COIL (4 REQ'D)
- (b) 3/4" HEX COIL NUT PVD. (8 REQ'D)
- (c) 3/4" WASHER CUT PLATED. (4 REQ'D)

ORDERING INFORMATION:

K42-BTV82-21 FOR ASSEMBLY AS SHOWN
 APPROVED FOR RIVERSIDE (BTE) PARKWAY.
 TOTAL ASSEMBLY WT. 4,273 Lbs.

1. BTV42-136-16, 36" INTERMEDIATE SECTION, WT. 1315 Lbs.
2. BTV42-136-11, 36" INTERMEDIATE SECTION, WT. 1320 Lbs.
3. BTV42-T6-21, 4" ROOF SECTION, WT. 1509 Lbs.
4. SG42-50G, PARKWAY COVER GRATE ASSEMBLY W/ BAFFLE PLASTIC, (4) 3/8"-13NC x 1 1/2" STAINLESS STEEL PENTAHEAD BOLTS, GALVANIZED ASS'Y, WT. 129 Lbs.
5. 5" x 6" K.O. x 2" DEEP. DRAFT AS FOLLOWS: T=1 3/8", S=1 3/8", S2=1 3/8", B=0". LOCATE AS FOLLOWS: (6) IN EACH INT. SECT. SHELL MTD.
6. 2 1/2" x 2 1/2" THRU HOLES TO ACCOMMODATE SWITCH SUPPORT CHANNELS. DRAFT AS FOLLOWS: T=1/2", S=1 1/2", S2=1/2", B=1/2". LOCATE (4) SHELL MTD. INT 136-3
7. 2 1/4" DIA K.O. x 2 1/4" DEEP. DRAFT AS FOLLOWS: 1/4" LOCATE (2) SHELL MTD. IN EACH INT. SECT.
8. 1 1/4" WIDE x 2 1/2" LONG x 1" DEEP GROOVE FOR BAFFLE. LOCATE (4) TABLE MTD. IN ROOF SECT.
9. 1/2" P-36-T INSERT, LOCATE (2) TABLE MTD. AND (4) RAIL MTD. IN ROOF SECT.
10. 3/8" P-25-T INSERT, LOCATE (8) TABLE MTD. IN ROOF SECT.
11. 1" x 2" x 3/16" SWITCH SUPPORT CHANNEL x 42" LONG (GALV) (75-30-20) (2) REQ. PER ASS'Y.
12. 3/4" x 5" COIL THD. BOLT & NUT FOR GRADE ADJUSTMENT (4) REQ. 38" x 38" SQUARE OF WEATHER RESISTANT CARDBOARD x 3/16" THICK, PAINTED BRIGHT ORANGE AND SECURED TO GRATE TO PREVENT DEBRIS FROM ENTERING ENCLOSURE AFTER INSTALLATION.

GENERAL NOTES:

1. Minimum soil bearing capacity is hereby assumed to be 2000 PSF unless otherwise documented by a geotechnical report that shall be provided to Jensen Precast by the end user. Jensen Precast shall not be held responsible for the soil bearing capacity.
2. Installation of Manholes, Vaults, Handholes, Meter Boxes etc. will be as per Jensen Installation procedures.
3. Structural modification to the Jensen line of products is not permitted without prior written approval from Jensen Engineering Department.
4. Do not scale the drawings, verify all dimensions including rough openings, if any discrepancies are found, notify the Jensen Engineer immediately.
5. The Jensen Engineer will interpret the intent of the drawings in case of possible conflict or discrepancy.
6. Permissible Variations:
 - Dimensional Tolerances – The length, width, height, or dia. measurements of the structure when measured on the inside surfaces shall not deviate from design dimensions by more than the following:
 - Dimensions: Tolerance:
 - 0 to 5 Feet 1/4"
 - 5 to 10 Feet 3/8"
 - 10 to 20 Feet as agreed upon between the supplier and purchaser.
 - Squareness Tolerance: The inside of the precast concrete component shall be square as determined by diagonal measurements. The difference between such measurements shall not exceed the following:
 - Measured Length: Allowable Difference
 - 0 to 10 Feet 1/2"
 - 10 to 20 Feet 3/4"
7. Between the supplier and purchaser.

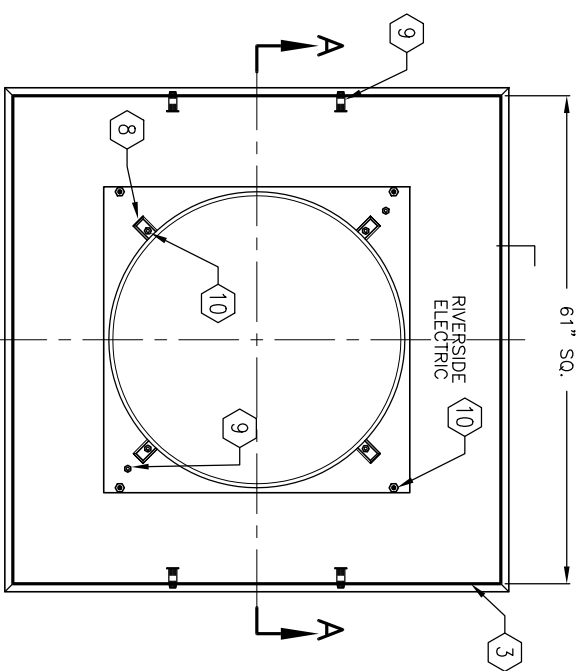
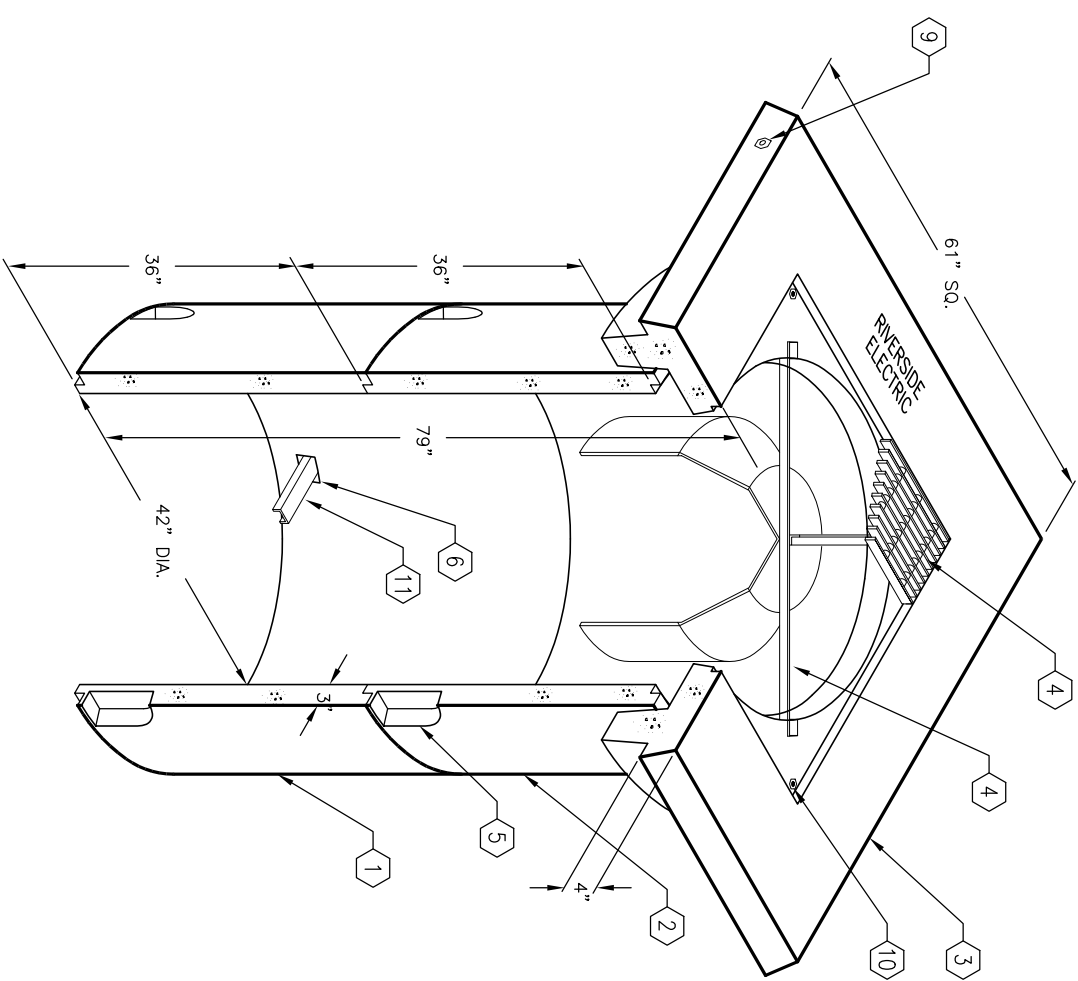

PLAN VIEW OF TOP CAP

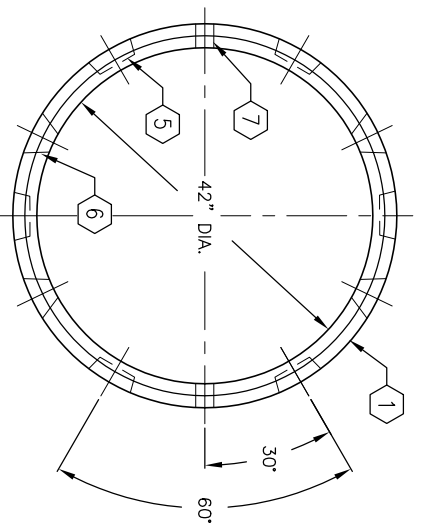

PLAN VIEW OF INTERMEDIATE

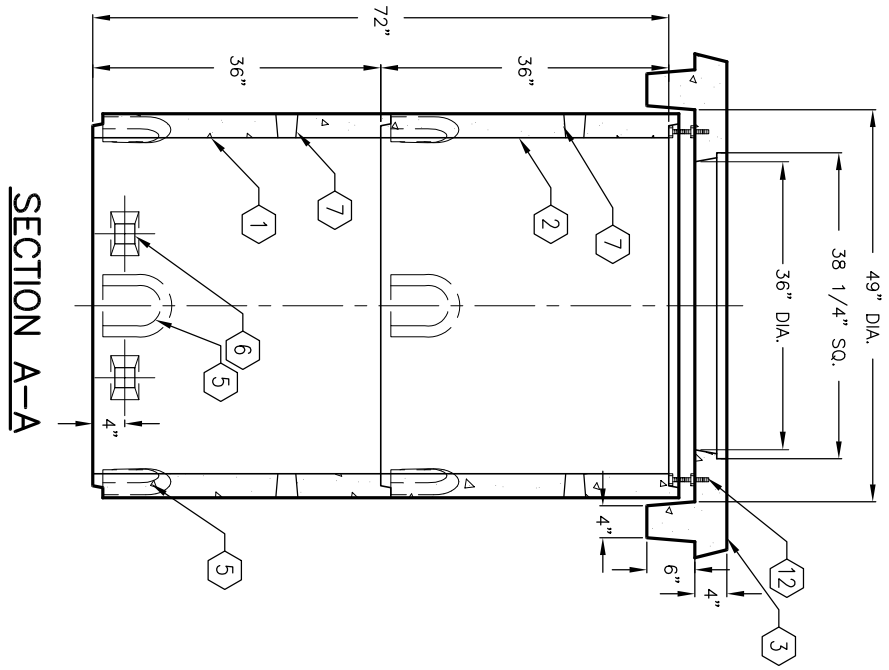

SECTION A-A

MINIMUM EXCAVATION SIZE:
 61" DIA. x DEPTH REQ'D, PLUS
 ALLOWANCE FOR ROOF SECTION



AUTOCAD REL. 14

K42-BTV82-21

PER RIVERSIDE (BTE) PARKWAY

03-01-02



#	DATE	DESCRIPTION	BY

K42-BTV82-21

PER RIVERSIDE (BTE) PARKWAY

03-01-02