

8'-0" x 9'-4" GLENDALE DUCTED TUNNEL VAULT x 14'-0" LONG

NOTES:

- DESIGNED IN ACCORDANCE WITH AASHTO H-20-44 BRIDGE LOADING USING 5,500 PSI [37.92MPa] COMPRESSIVE STRENGTH CONCRETE AND 60,000 PSI [413.2MPa] YIELD STRENGTH GRADE 60 A-706 REINFORCEMENT PER CALC. #30344.
- VAULT TO BE PLACED ON A 6" BASE OF CRUSHER RUN FOR EASE OF INSTALLATION AND EVEN LOAD DISTRIBUTION.
- LIMIT OF COVER OVER ROOF SECTION IS 1'-0" TO 4'-0".

THE FOLLOWING MATERIAL TO BE SHIPPED WITH EACH VAULT:

- (a) 7/8" x 1 3/4" CONSEAL GASKET (135 FT. REQ'D.)

ORDERING INFORMATION:

K894-TV14-192 FOR ASSEMBLY AS SHOWN.
APPROVED FOR GLENDALE SPECS.
TOTAL WEIGHT OF ASSEMBLY IS 61,000 Lbs.

GENERAL NOTES:

1. Minimum soil bearing capacity is hereby assumed to be 2000 PSF unless otherwise documented by a geotechnical report that shall be provided to Jensen Precast by the end user. Jensen Precast shall not be held responsible for the soil bearing capacity.
2. Installation of Manholes, Vaults, Handholes, Meter Boxes etc. will be as per Jensen installation procedures.
3. Structural modification to the Jensen line of products is not permitted without prior written approval from Jensen Engineering Department.
4. Do not scale the drawings, verify all dimensions including rough openings, if any discrepancies are found, notify the Jensen Engineer immediately.
5. The Jensen Engineer will interpret the intent of the drawings in case of possible conflict or discrepancy.
6. Permissible Variations: - The length, width, height, or dia. measurements of the structure when measured on the inside surfaces shall not deviate from design dimensions by more than the following:
Dimensions: Tolerance:
0 to 5 Feet 1/4"
5 to 10 Feet 3/8"
10 to 20 Feet as agreed upon between the supplier and purchaser.
Squareness Tolerance:
The inside of the precast concrete component shall be square as determined by diagonal measurements. The difference between such measurements shall not exceed the following:
Measured Length: Allowable Difference
0 to 10 Feet 1/2"
10 to 20 Feet 3/4"
20 Feet and over as agreed upon between the supplier and purchaser.
- 7.

1. TV894-C96-19, 96" CENTER SECTION, WT. 26,000 lbs.
3. TV894-E36-192, 36" END SECTION-DUCTED, WT. 17,500 lbs.
4. EACH (2) REQ'D.
- 13" x 14" DIA. SUMP x 5" DEEP W/GRATE RECESS TO ACCOMMODATE SUMP COVER. LOCATE AS FOLLOWS: CENTER SECTION (1) CORE MTD. 18" x 75" DEEP DUCT K.O. x 12" DEEP W/(12) 5" DIA. CONTERMS. (8) 5" DIA. K.O. x 2" DEEP, (1) 2" x 2 1/2" DIA. K.O. x 2" DEEP. DRAFT AS FOLLOWS: T=1" S1=1" S2=7", B=7". LOCATE AS FOLLOWS: END SECTIONS (2) EACH CORE MTD.
- 10" DIA. VENT K.O. x 5" DEEP. LOCATE AS FOLLOWS: CENTER SECTION (4) CORE MTD.; END SECTIONS, (1) EACH CORE MTD.
- 5/8" COPPER CLAD STEEL GROUND ROD x 14" LONG. LOCATE AS FOLLOWS: END SECTIONS (1) EACH CORE MTD.
- 1" DIA. BLIND GROUND ROD HOLE. LOCATE AS FOLLOWS: END SECTIONS (1) EACH CORE MTD.
- 1 5/8" x 1 5/8" GALVANIZED UNISTRUIT. LOCATE AS FOLLOWS: CENTER SECTION (6) x 96" LONG CORE MTD.; END SECTIONS (3) EACH x 32" LONG CORE MTD., (6) EACH x 23 3/4" LONG. CORE MTD.
- 1" GALV. DOUBLE COIL THRD. INSERT. LOCATE AS FOLLOWS: CENTER SECTION (1) CORE MTD.; END SECTIONS (4) EACH CORE MTD.
- 1" GALV. COIL THRD. INSERT. LOCATE AS FOLLOWS: CENTER SECTION (8) CORE MTD.; END SECTIONS (2) EACH CORE MTD.
- 1/2" P-35-T INSERT. LOCATE AS FOLLOWS: CENTER SECTION (16) CORE MTD.; END SECTIONS (10) EACH CORE MTD.
- BOLT-UP CASTINGS. LOCATE AS FOLLOWS: CENTER SECTION (8) CORE MTD.; END SECTS. (4) EACH CORE MTD.

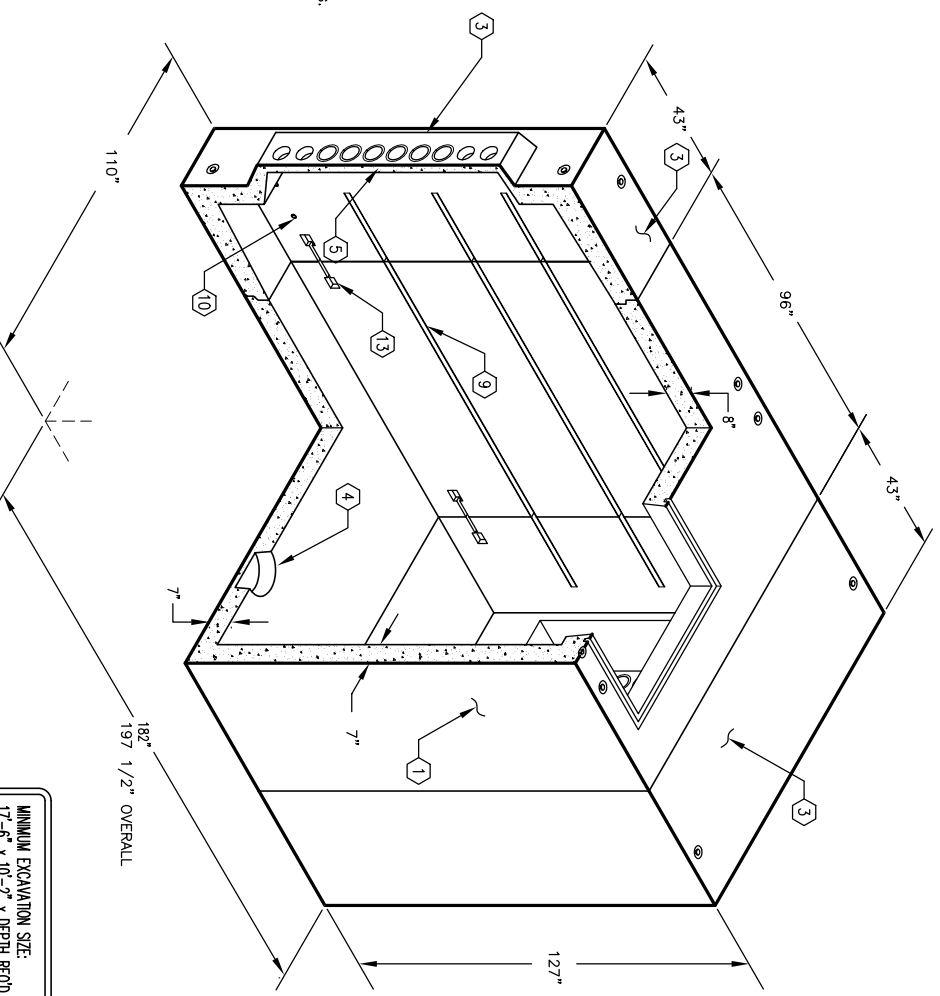

MINIMUM EXCAVATION SIZE:
17'-6" x 10'-2" x DEPTH REQ'D.

K894-TV14-192
PER GLENDALE SPECS. 03-01-02



AUTOCAD REL. 14

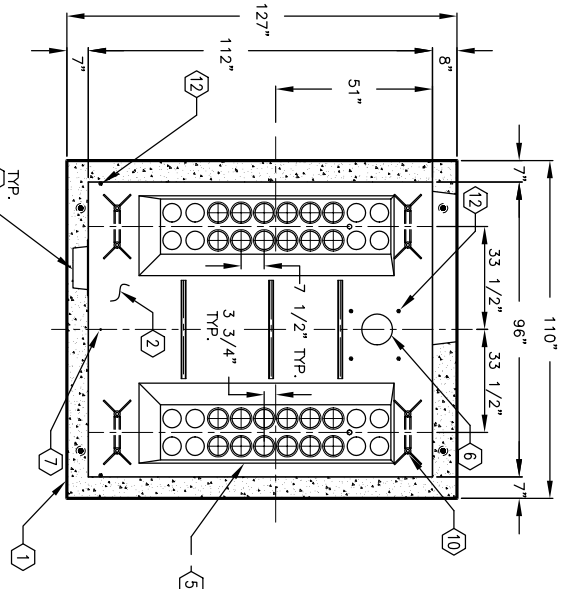
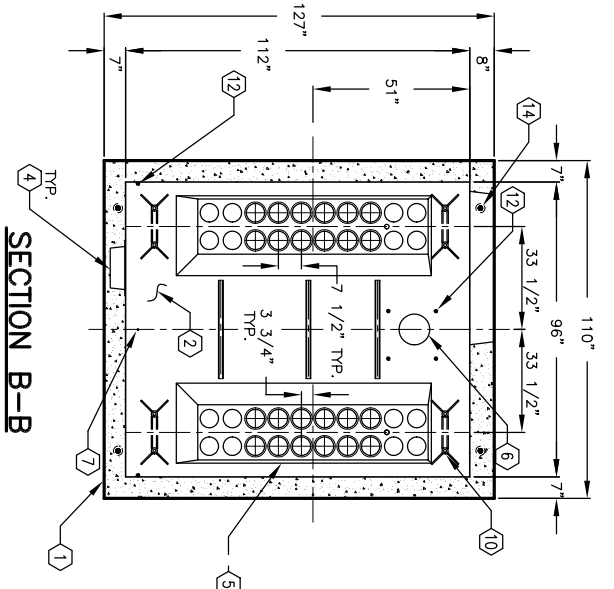
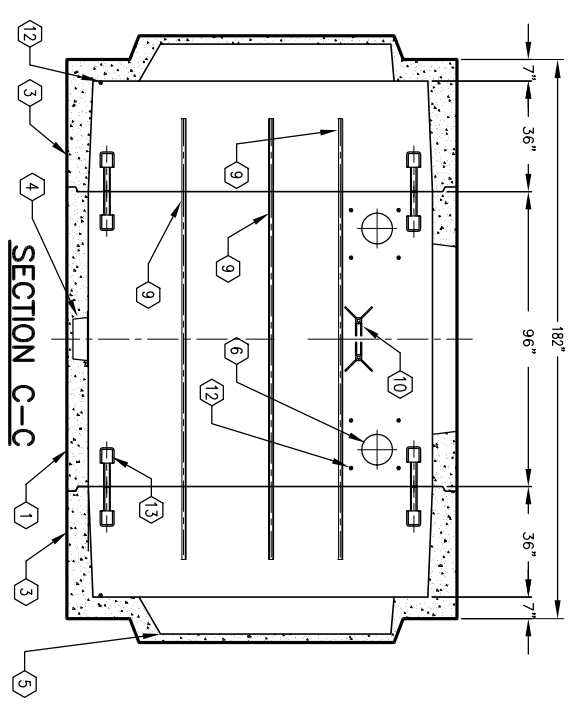
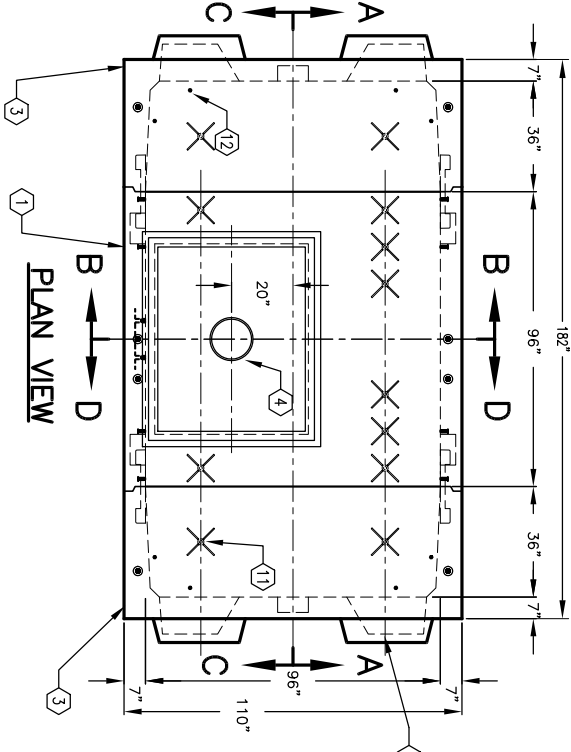
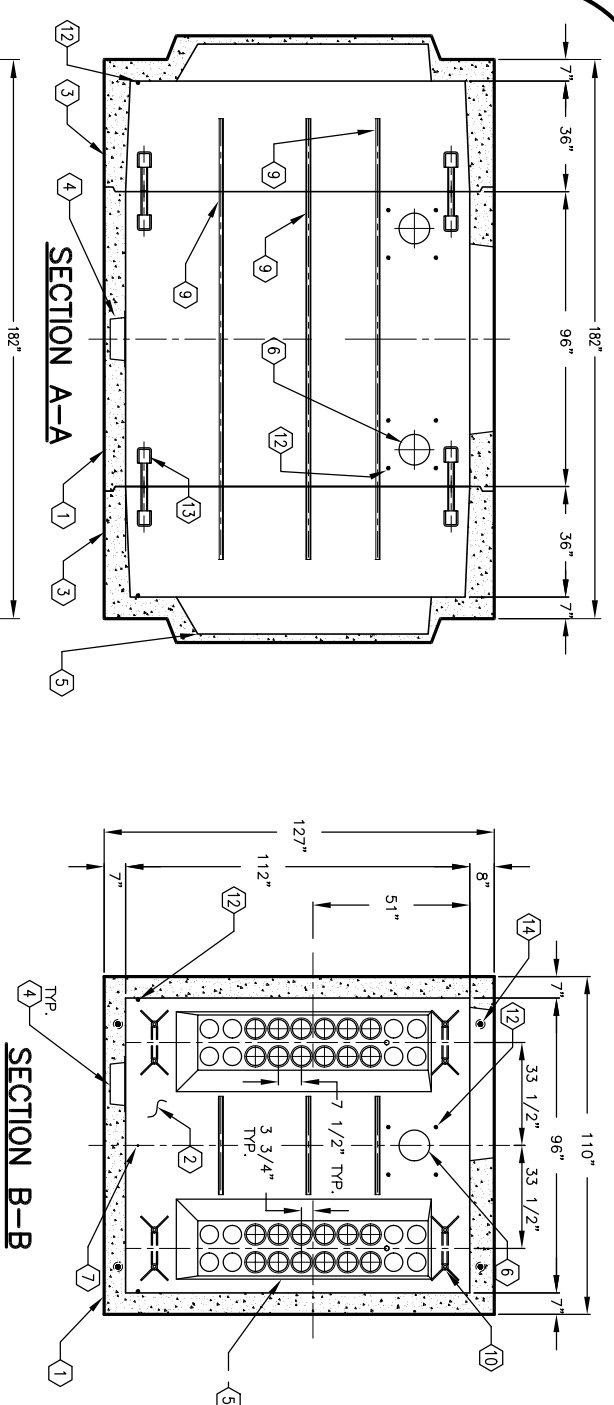

#	DATE	DESCRIPTION	BY

K894-TV14-192
PER GLENDALE SPECS. 03-01-02

