

8'-0" x 14'-0" TRAFFIC CITY OF CORONA VAULT x 9'-4" DEEP

NOTES:

- VAULT DESIGNED IN ACCORDANCE WITH AASHTO H-20-44 TRAFFIC BRIDGE LOADING USING 5,500 PSI [37.92MPa] COMPRESSIVE STRENGTH CONCRETE AND 60,000 PSI [413.2MPa] YIELD STRENGTH ASTM A-706 STEEL REINFORCEMENT PER CALCS. #31008.
 - VAULT TO BE PLACED ON A MIN. 6" BASE OF CRUSHER RUN FOR EASE OF INSTALLATION AND EVEN LOAD DISTRIBUTION.
 - INTERIOR WALLS AND CEILING SHALL BE PAINTED WITH TWO COATS WHITE PAINT. (FRAZEE #410 LATEX OR APPROVED EQUAL).
 - ALL JOINTS SHALL BE GASKETED WATERTIGHT.
- THE FOLLOWING TO BE INSTALLED WITH VAULT:**
- a) 1 5/8" x 1 5/8" GALV. BOLT ON UNISTRUT x 48" LONG. (24 REQ'D.).
W/ 1/2" DIA. ROUNDHEAD BOLT & WASHER (72 REQ'D.).

ORDERING INFORMATION:

K814-FV112-39 FOR ASSEMBLY AS SHOWN.
PER CITY OF CORONA SPEC.
TOTAL WEIGHT OF ASSEMBLY AS SHOWN IS 66,870 Lbs.

GENERAL NOTES:

1. Minimum soil bearing capacity is hereby assumed to be 2000 PSF unless otherwise documented by a geotechnical report that shall be provided to Jensen Precast by the end user. Jensen Precast shall not be held responsible for the soil bearing capacity.
2. Installation of Manholes, Vaults, Handholes, Meter Boxes etc. will be as per Jensen installation procedures.
3. Structural modification to the Jensen line of products is not permitted without prior written approval from Jensen Engineering Department.
4. Do not scale the drawings, verify all dimensions including rough openings, if any discrepancies are found, notify the Jensen Engineer immediately.
5. The Jensen Engineer will interpret the intent of the drawings in case of possible conflict or discrepancy.
6. Permissible Variations:
Dimensional Tolerances - The length, width, height, or dia. measurements of the structure when measured on the inside surfaces shall not deviate from design dimensions by more than the following:
Dimensions: Tolerance:
0 to 5 Feet 1/4"
5 to 10 Feet 3/8"
10 to 20 Feet as agreed upon between the supplier and purchaser.
7. Squareness Tolerance:
The inside of the precast concrete component shall be square as determined by diagonal measurements. The difference between such measurements shall not exceed the following:
Measured Length: Allowable Difference
0 to 10 Feet 1/2"
10 to 20 Feet 3/4"
20 Feet and over as agreed upon between the supplier and purchaser.

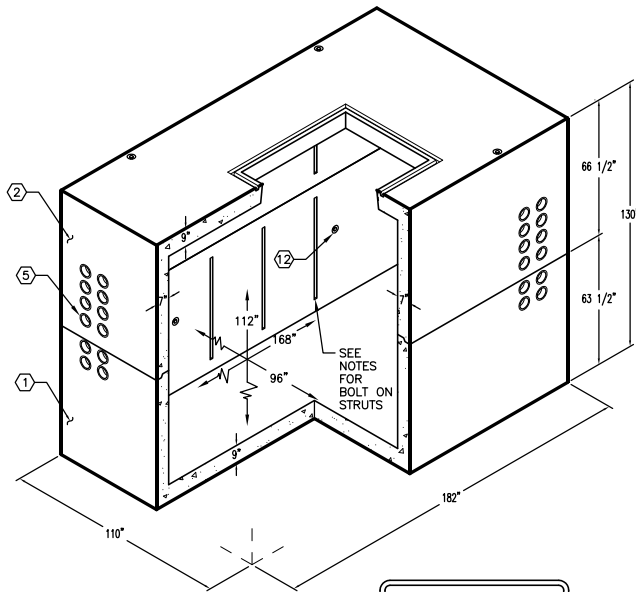

MINIMUM EXCAVATION SIZE:
10'-2" x 16'-2" x DEPTH REQ'D.

K814-FV112-39

PER CITY OF CORONA SPEC. 04-21-03

JENSEN PRECAST

AUTOCAD 2000

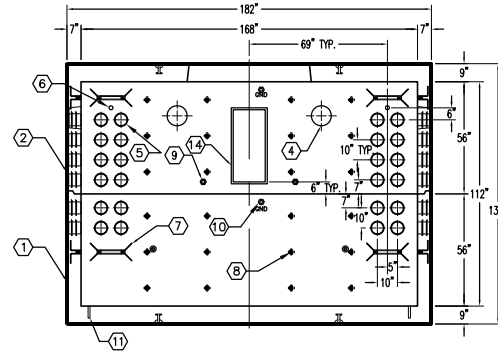

SECTION A-A

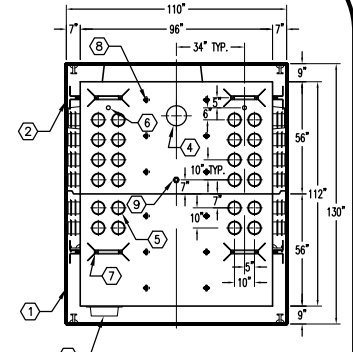

SECTION B-B

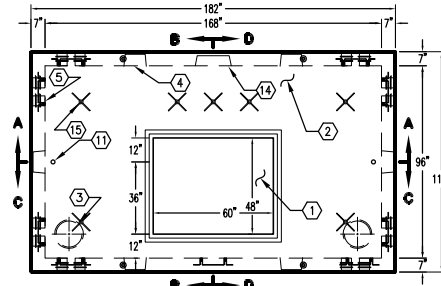

PLAN VIEW

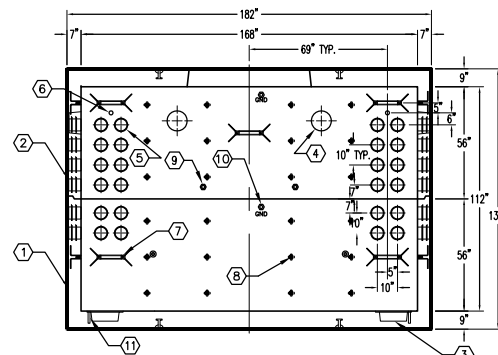

SECTION C-C

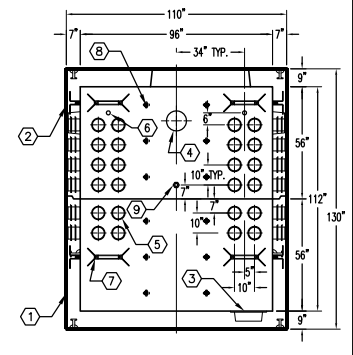

SECTION D-D

JENSEN PRECAST

#	DATE	DESCRIPTION	BY
A	05-27-04	REVISED JOINT	SMC

K814-FV112-39

PER CITY OF CORONA SPEC. 04-21-03