

5'-0" x 8'-6" LIGHT TRAFFIC FLAT WALL TRANSFORMER ENCLOSURE x 84" DEEP

NOTES:

- VAULT DESIGNED IN ACCORDANCE WITH AASHTO H-20-44 TRAFFIC BRIDGE LOADING USING 5,500 PSI [37.92MPa] COMPRESSIVE STRENGTH CONCRETE AND 60,000 PSI [413.2MPa] YIELD STRENGTH ASTM A-706 STEEL REINFORCEMENT PER CALCS. #31673.
- COVER DESIGNED FOR TRAFFIC OFF STREET LOADING. PER CALCS.
- VAULT TO BE PLACED ON A MIN. 6" BASE OF CRUSHER RUN FOR EASE OF INSTALLATION AND EVEN LOAD DISTRIBUTION.
- ALL INTERIOR SURFACES SHALL BE PAINTED WITH TWO COATS OF FLAT LATEX WHITE PAINT (FRAZEE #410 OR EQUAL).

THE FOLLOWING MATERIAL TO BE SHIPPED WITH EACH VAULT:
 (a) 7/8" x 1 3/4" CONSEAL GASKET (45 FT. REQ'D.)

ORDERING INFORMATION:

K586-FTE84-COR-T FOR ASSEMBLY AS SHOWN.
 APPROVED FOR CITY OF CORONA
 TOTAL WEIGHT OF ASSEMBLY AS SHOWN. 19,732 lbs.

GENERAL NOTES:

1. Minimum soil bearing capacity is hereby assumed to be 2000 PSF unless otherwise documented by a geotechnical report that shall be provided to Jensen Precast by the end user. Jensen Precast shall not be held responsible for the soil bearing capacity.
2. Installation of Manholes, Vaults, Handholes, Meter Boxes etc. will be as per Jensen installation procedures.
3. Structural modification to the Jensen line of products is not permitted without prior written approval from Jensen Engineering Department.
4. Do not scale the drawings, verify all dimensions including rough openings, if any discrepancies are found, notify the Jensen Engineer immediately.
5. The Jensen Engineer will interpret the intent of the drawings in case of possible conflict or discrepancy.
6. Permissible Variations:
 Dimensional Tolerances - The length, width, height, or dia. measurements of the structure when measured on the inside surfaces shall not deviate from design dimensions by more than the following:
 Dimensions: Tolerance:
 0 to 5 Feet 1/8"±
 5 to 10 Feet 1/8"±
 10 to 20 Feet as agreed upon between the supplier and purchaser.
 Squareness Tolerance:
 The inside of the precast concrete component shall be square as determined by diagonal measurements. The difference between such measurements shall not exceed the following:
 Measured Length: Allowable Difference
 0 to 10 Feet 3/16"±
 10 to 20 Feet 3/8"±
 20 Feet and over as agreed upon between the supplier and purchaser.
- 7.

1. PB586-B42-21 42" BOTTOM SECTION (CG-586-B42-21 (262), WT. 11,888 lbs.
2. PB586-TR37-21 37" TOP SECTION (CG-586-TR37-21 (263), WT. 6,344 lbs.
3. CAS86-TGSRSAV-21, LOOSE ADJUSTABLE GALVANIZED FRAME WITH SC586-21-T TWO PIECE HINGED TRAFFIC GALV. SLIP RESISTANT COVER & GRATE ASSEMBLY. WITH (11) REMOVABLE SUPPORT BEAMS.
4. 13" x 14" DIA. SUMP x 5" DEEP W/GRATE & RECESS. BOTTOM SECTION (1) CORE MTD.
5. 5" DIA. TERMS. BOTTOM SECTION (48) CORE MTD. TOP SECTION (32) CORE MTD.
6. 14" DIA. VENT KNOCKOUT. TOP SECTION (2) CORE MTD.
7. 1" DIA. GROUND ROD KNOCKOUT. BOTTOM SECTION (2) CORE MTD.
8. 7/8" DIA. x 4 1/2" GALVANIZED PULL IRON WITH LEGS (05-2140). LOCATE AS FOLLOWS: BOTTOM SECTION (8) CORE MTD.
11. 1/2" THR'D. BRONZE INSERT BRAZED TO STRUCTURAL STEEL. "GRD" SHALL BE STENCILED IN RED LETTERS (1 1/2" MIN. TO 2" MAX) ON THE CONCRETE ABOVE EA. INSERT. BOTTOM SECTION (2) CORE MTD.; ROOF SECTION (2) CORE MTD.

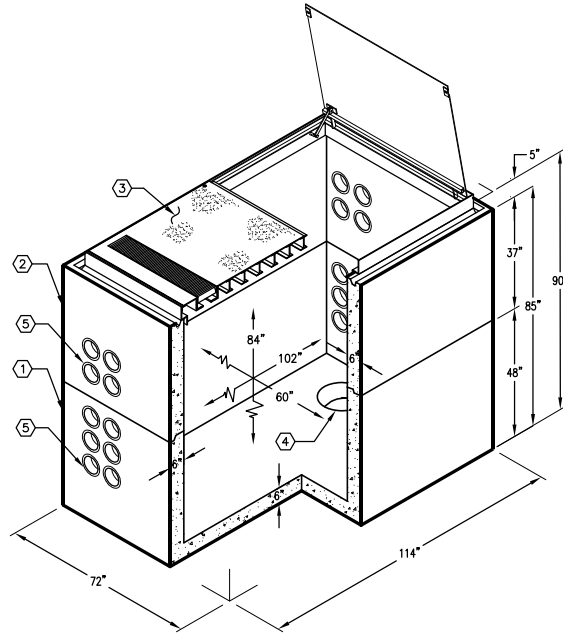

MINIMUM EXCAVATION SIZE:
 7'-0" x 10'-6" x DEPTH REQ'D.



K586-FTE84-COR-T

PER CITY OF CORONA 04-29-03

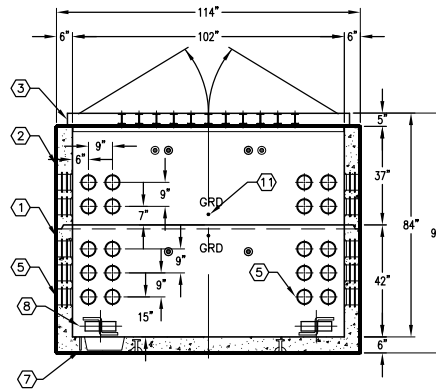

SECTION A-A

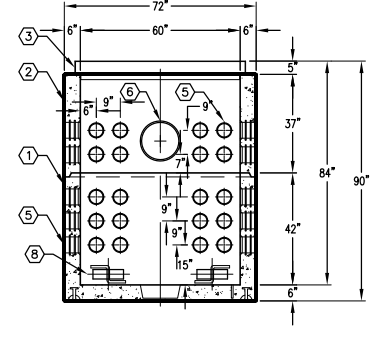

SECTION B-B

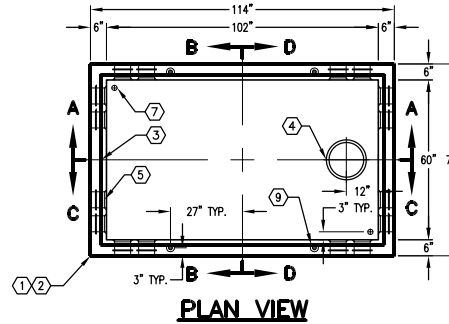

PLAN VIEW

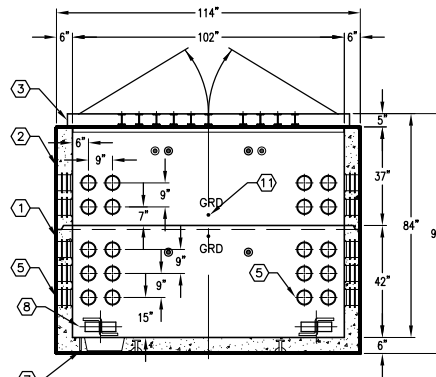

SECTION C-C

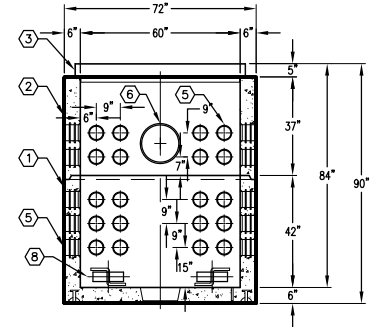

SECTION D-D



K586-FTE84-COR-T

PER CITY OF CORONA 04-29-03

#	DATE	DESCRIPTION	BY