

3'-0" x 5'-0" CITY OF CORONA DUCTED PULL BOX x 50" DEEP

NOTES:

- PULL BOX DESIGNED IN ACCORDANCE WITH AASHTO H-20-44 TRAFFIC BRIDGE LOADING USING 5,500 PSI COMPRESSIVE STRENGTH CONCRETE AND 60,000 PSI YIELD STRENGTH ASTM A-706 STEEL REINFORCEMENT.
 - PULL BOX TO BE PLACED ON A MIN. 6" BASE OF CRUSHER RUN FOR EASE OF INSTALLATION AND EVEN LOAD DISTRIBUTION.
1. PB3660D-B42-05, 42" BOTTOM SECTION, WT. 4,448 lbs.
 2. PB3660-T8A, 8" TOP SECTION, W/GALV. ANGLE FRAME CAST-IN, WT. 548 lbs.
 - 3A. SC3660-TGV, TWO PIECE TRAFFIC COVER, GALVANIZED FINISH, MARKED "CORONA ELECTRIC, WT. 426 lbs. (AS SHOWN)
 - 3B. 12-20-XX, TWO PIECE RPM PARKWAY COVER, MARKED "CORONA ELECTRIC". (NOT SHOWN)
 4. 6" x 7" DIA. SUMP x 2" DEEP, BOTTOM SECTION.
 5. 26" x 26 1/2" DUCTED K.O. x 12" DEEP, BOTTOM SECTION.
 6. 10" x 16" K.O. x 3" DEEP, BOTTOM SECTION.
 7. 1" DIA. BLIND GROUND ROD HOLE, BOTTOM SECTION.
 8. 1/2" P-35-T INSERT W/CLEAN-OUT HOLE, TOP SECTION.
 9. 7/8" DIA. X 9" GALV. VERTICAL PULL IRON, BOTTOM SECTION.

ORDERING INFORMATION:

APPROVED PER CITY OF CORONA SPEC.
TOTAL WEIGHT OF ASSEMBLY SHOWN IS 5,433 lbs.

LIGHT TRAFFIC ASSEMBLY WITH STEEL COVER K3660-DP50-39T.
PARKWAY ASSEMBLY WITH RPM COVER K3660-DP50-39P.

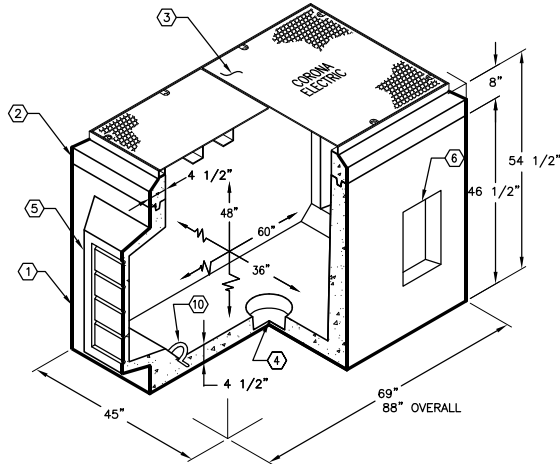

K3660-DP50-39

PER CITY OF CORONA SPEC. 04-23-04

MINIMUM EXCAVATION SIZE:
4'-1" x 7'-6" x DEPTH REQ'D.

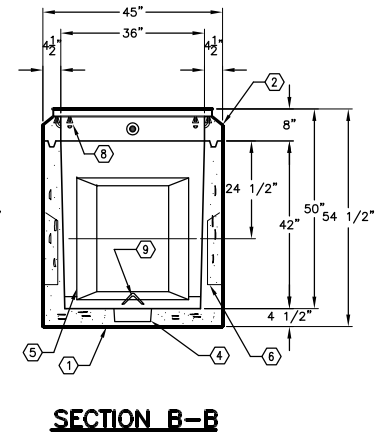
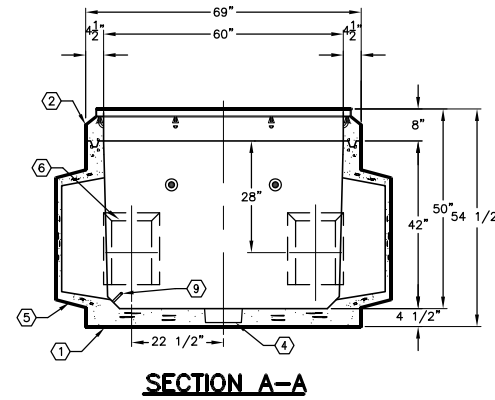
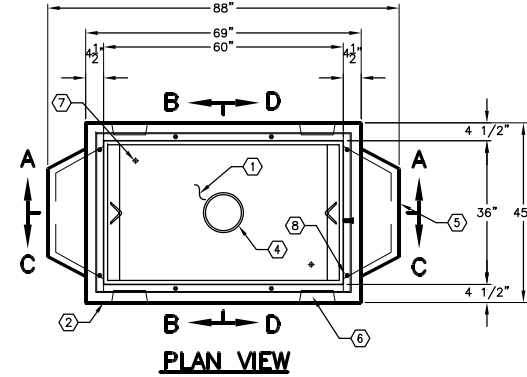

K3660-DP50-39

PER CITY OF CORONA SPEC. 04-23-04

#	DATE	DESCRIPTION	BY