

**10'-0" x 12'-0" CITY OF CORONA TRANSFORMER PAD W/5'-0" x 8'-6" ENCLOSURE x 60" DEEP**

**NOTES:**

- DESIGNED FOR H-20-44 TRAFFIC LOADING USING 5,500 P.S.I. CONCRETE AND 60,000 P.S.I. (GRADE 60) REINFORCING STEEL PER CALCS. # 30500.
- COVER DESIGNED FOR PARKWAY LOADING.
- ALL INTERIOR SURFACES SHALL BE PAINTED WITH ONE COAT OF FLAT LATEX WHITE PAINT.
- SWITCH ENCLOSURE TO BE PLACED IN A 6" BASE CRUSHER RUN FOR EASE IN INSTALLATION AND EVEN LOAD DISTRIBUTION.

**ORDERING INFORMATION:**

- K586-SB60-39 FOR ASSEMBLY AS SHOWN. APPROVED FOR CITY OF CORONA.
- WEIGHT FOR ASSEMBLY IS SHOWN 27,570 lbs.
- MASTIC SEALANT TO BE ADDED TO JOINTS.

1. SB586-B61-11, 61" BOTTOM SECTION, WT. 15,400 lbs.
2. PD120144-T8-11, 8" THICK TOP SLAB, W/(1) F3048-PB-ANG CAST-IN GALV. ANGLE FRAME, WT. 12,060 lbs.
3. 3048 RPM COVER MARKED "CORONA ELECTRIC" W/(6) 1/2" x 2 1/2" P.H.S.S. BOLTS W/CAPTIVE WASHER (2) LIFT EYES, WT. 109 lbs.
4. 13" x 14" DIA. SUMP x 3" DEEP, W/REGRESS TO ACCOMADATE SUMP COVER. LOCATE AS FOLLOWS: BOTTOM SECTION (1) CORE MTD.
5. 5" CENTERMS (55636). LOCATE AS FOLLOWS: BOTTOM SECTION (28) SHELL MTD.
6. 7/8" DIA. c 6" GALVANIZED PULL IRON. LOCATE AS FOLLOWS: BOTTOM SECTION (4) CORE MTD.
8. 4 TON x 9" GALVANIZED RISS ANCHOR FOR HANDLING. LOCATE AS FOLLOWS: BOTTOM SECTION (4) SURFACE MTD.
9. 1/2" P-5000 PLASTIC INSERT. LOCATE AS FOLLOWS: BOTTOM SECTION (18) CORE MTD.
10. 1/2" P-35-T INSERT W/CLEAN OUT HOLE LOCATE AS FOLLOWS: TRANSFORMER PAD (6) FRAME MTD.
11. 1 5/8" x 1 5/8" UNISTRUT 14" LONG. LOCATE AS FOLLOWS: TRANSFORMER PAD (2) TABLE MTD.
12. 1" DIA. SCH. 40 PVC CONDUIT CAPPED AT OUTSIDE WALL. LOCATE AS FOLLOWS: BOTTOM SECTION (2) CORE MTD.
13. 7/8" DIA. x 3 3/8" GALVANIZED FLUSH PULL IRON. LOCATE AS FOLLOWS: BOTTOM SECTION (4) CORE MTD.
14. 1" x 5 1/2" GALVANIZED COIL THREADED INSERT. LOCATE AS FOLLOWS: TRANSFORMER PAD (4) TABLE MTD.

**GENERAL NOTES:**

1. Minimum soil bearing capacity is hereby assumed to be 2000 PSF unless otherwise documented by a geotechnical report that shall be provided to Jensen Precast by the end user. Jensen Precast shall not be held responsible for the soil bearing capacity.
2. Installation of Manholes, Vaults, Handholes, Meter Boxes etc. will be as per Jensen installation procedures.
3. Structural modification to the Jensen line of products is not permitted without prior written approval from Jensen Engineering Department.
4. Do not scale the drawings, verify all dimensions including rough openings, if any discrepancies are found, notify the Jensen Engineer immediately.
5. The Jensen Engineer will interpret the intent of the drawings in case of possible conflict or discrepancy.
6. Permissible Variations:  
 Dimensional Tolerances - The length, width, height, or dia. measurements of the structure when measured on the inside surfaces shall not deviate from design dimensions by more than the following:  
 Dimensions:                      Tolerance:  
 0 to 5 Feet                      1/4"  
 5 to 10 Feet                      3/8"  
 10 to 20 Feet as agreed upon between the supplier and purchaser.  
 Squariness Tolerance:  
 The inside of the precast concrete component shall be square as determined by diagonal measurements. The difference between such measurements shall not exceed the following:  
 Measured Length: Allowable Difference  
 0 to 10 Feet                      1/2"  
 10 to 20 Feet                      3/4"  
 20 Feet and over as agreed upon between the supplier and purchaser.

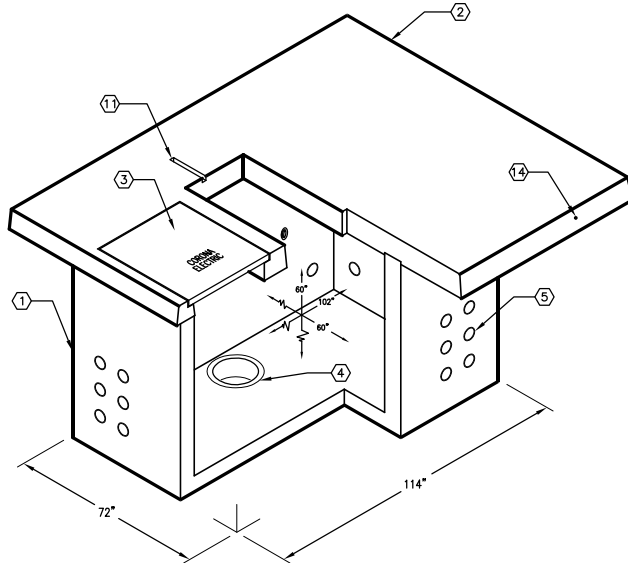

MINIMUM EXCAVATION SIZE:  
7'-6" x 11'-0" x 60" DEPTH REQD.

**K586-SB60-39**

PER CITY OF CORONA 04-23-04



AUTOCAD REL. 14

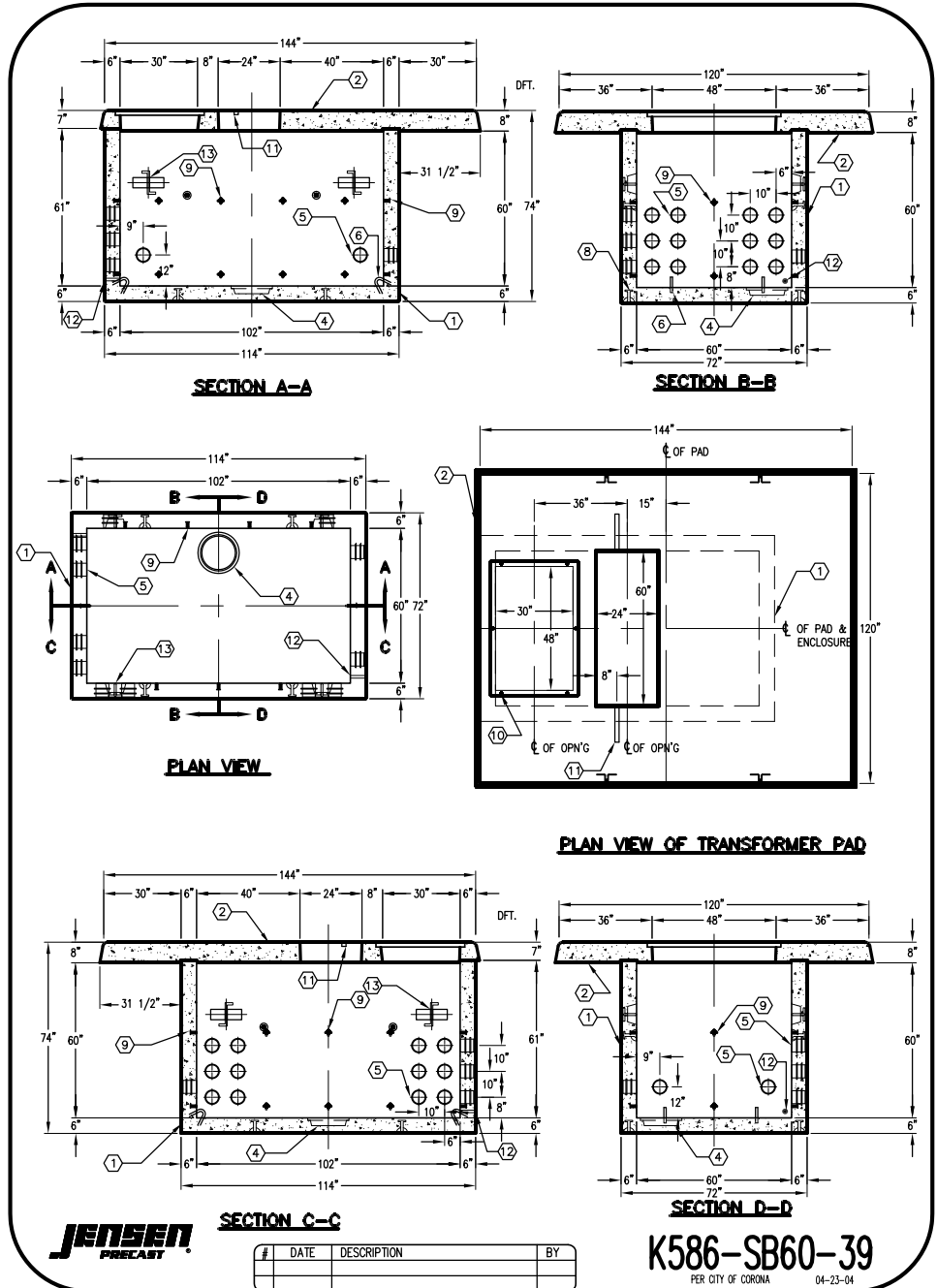

**K586-SB60-39**

PER CITY OF CORONA 04-23-04

#	DATE	DESCRIPTION	BY