

3'-6" DIA. ANAHEIM BURD TRANSFORMER ENCLOSURE X 3'-7" DEEP

NOTES:

TRANSFORMER ENCLOSURE DESIGNED FOR PARKWAY LOADING CONDITION USING 5,500 PSI [37.92MPa] COMPRESSIVE STRENGTH CONCRETE AND 60,000 PSI [413.2MPa] YIELD STRENGTH ASTM A-706 STEEL REINFORCEMENT PER CALCS. #30204.

TRANSFORMER ENCLOSURE TO BE PLACED ON A 6" BASE OF CRUSHER RUN FOR EASE OF INSTALLATION AND EVEN LOAD DISTRIBUTION.

THE FOLLOWING MATERIAL TO BE SHIPPED WITH THE TRANSFORMER ENCLOSURE:

- (d) 3/4" x 4" COIL BOLT (4 REQ'D.)
- (b) 3/4" HEX COIL NUT PYD (8 REQ'D.)
- (c) 3/4" CUT WASHER PLATED (4 REQ'D.)
- (c) 7/8" x 1 3/4" CONSEAL GASKET (45 FT. REQ'D)

ORDERING INFORMATION:

K42-BTV43-16 FOR ASSEMBLY AS SHOWN.
PER CITY OF ANAHEIM SPEC. CU 1600-14
TOTAL WEIGHT OF ASSEMBLY IS 2,960 Lbs.

GENERAL NOTES:

1. Minimum soil bearing capacity is hereby assumed to be 2000 PSF unless otherwise documented by a geotechnical report that shall be provided to Jensen Precast by the end user. Jensen Precast shall not be held responsible for the soil bearing capacity.
2. Installation of Manholes, Valuts, Handholes, Meter Boxes etc. will be as per Jensen installation procedures.
3. Structural modification to the Jensen line of products is not permitted without prior written approval from Jensen Engineering Department.
4. Do not scale the drawings, verify all dimensions including rough openings, if any discrepancies are found, notify the Jensen Engineer immediately.
5. The Jensen Engineer will interpret the intent of the drawings in case of possible conflict or discrepancy.
6. Permissible Variations:
Dimensional Tolerances – The length, width, height, or dia. measurements of the structure when measured on the inside surfaces shall not deviate from design dimensions by more than the following:
Dimensions: Tolerance:
0 to 5 Feet 1/4"
5 to 10 Feet 3/8"
10 to 20 Feet as agreed upon between the supplier and purchaser.
Squareness Tolerance:
The inside of the precast concrete component shall be square as determined by diagonal measurements. The difference between such measurements shall not exceed the following:
Measured Length: Allowable Difference
0 to 10 Feet 1/2"
10 to 20 Feet 3/4"
20 Feet and over as agreed upon between the supplier and purchaser.
- 7.

1. BTV42-136-16, 36" INTERMEDIATE SECTION, WT. 1315 Lbs.
2. BTV42-T6-16, 6" TOP SLAB, WT. 1509 Lbs.
3. SC42-GVE, PARKWAY COVER ASSEMBLY W/3/16" GALV. SAFETY FLOOR PLATE, (2) 3/8" x 1 1/2" HEX HEAD CAP SCREWS PLATED BOLT DOWNS, 1" DIA. LIFT HOLES GALV. TAMPER PLATE BELOW, GALV. FINISH ASSEMBLY, MARKED "ELECTRIC", WT. 136 Lbs.
4. 5" x 6" K.O. x 2" DEEP. DRAFT AS FOLLOWS:
T=1 3/8", S1 & S2=1 3/8", B=0. LOCATE AS FOLLOWS:
INTERMEDIATE SECTION (6) SHELL MTD.
5. 1 1/4" DIA. K.O. x 2 1/4" DEEP. DRAFT AS FOLLOWS:
1/4". LOCATE AS FOLLOWS: INTERMEDIATE SECTION (2) CORE MTD.
6. 1 1/2" P-35-T OB INSERT. LOCATE AS FOLLOWS: ROOF SECTION
7. (2) TABLE MTD., (4) RAIL MTD. INTERMEDIATE SECTION (2) CORE MTD.
8. (3/8" P-25-T OB INSERT. LOCATE AS FOLLOWS: ROOF SECTION (4) TABLE MTD.
9. 5/8" DIA. ADJUSTING BOLT, (4) PLS.

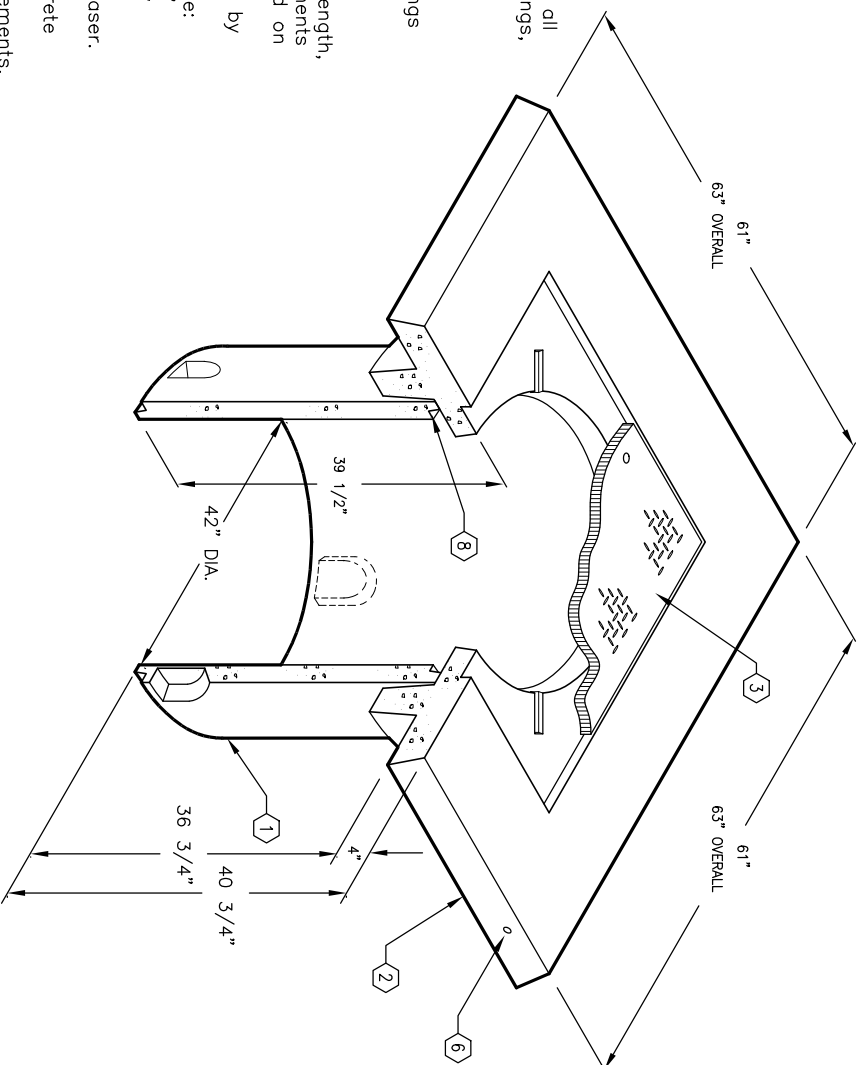

MINIMUM EXCAVATION SIZE:
61" DIA. x DEPTH REQ'D. PLUS
ALLOWANCE FOR ROOF SECTION

K42-BTV43-16

PER CITY OF ANAHEIM SPEC. CU 1600-14

03-01-02

JENSEN PRECAST

| # | DATE | DESCRIPTION | BY |
|---|------|-------------|----|
| | | | |

K42-BTV43-16

PER CITY OF ANAHEIM SPEC. CU 1600-14

03-01-02

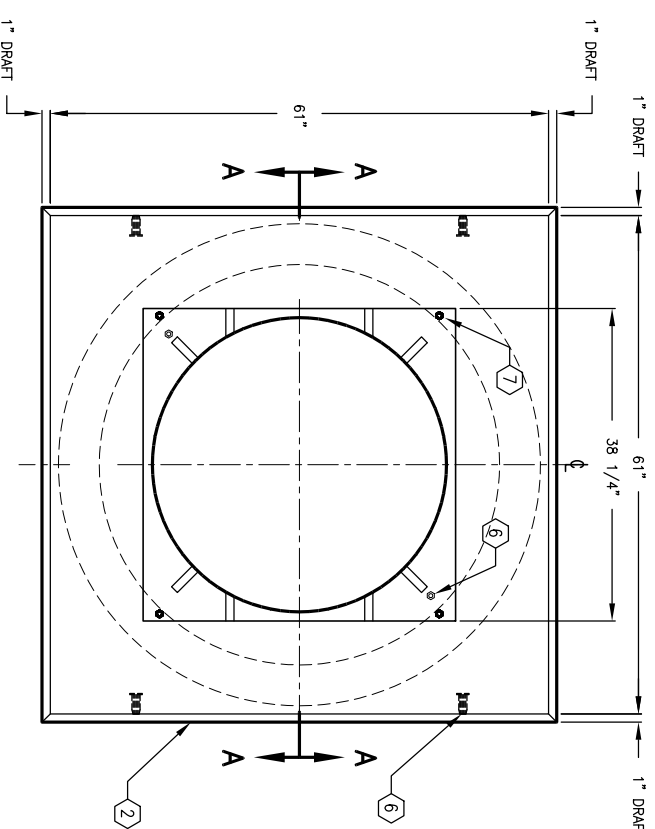

PLAN VIEW OF ROOF SECTION

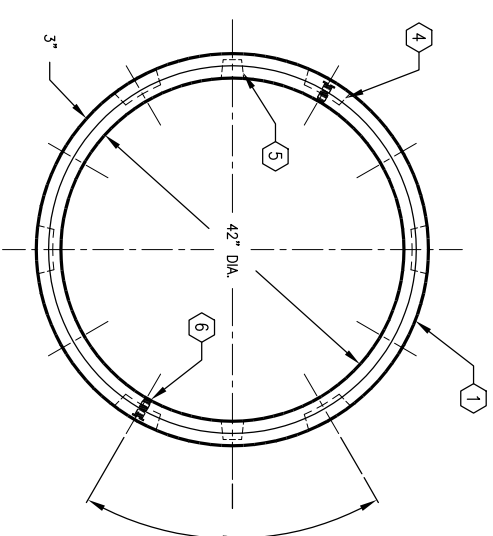

PLAN VIEW OF INTERMEDIATE

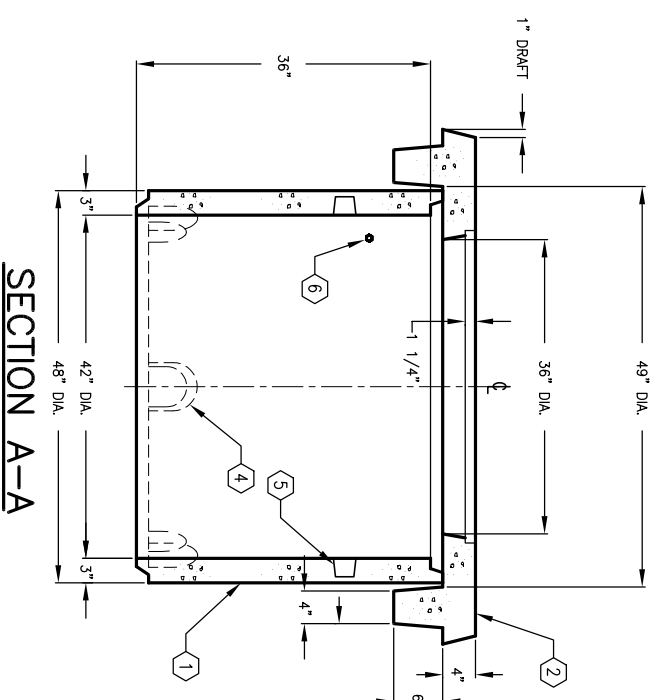

SECTION A-A