

# 2'-6" x 4'-0" ANAHEIM DUCTED PULL BOX x 3'-0" DEEP

**NOTES:**

- PULL BOX DESIGNED IN ACCORDANCE WITH AASHTO H-20-44 TRAFFIC BRIDGE LOADING USING 5,500 P.S.I. COMPRESSIVE STRENGTH CONCRETE AND 60,000 P.S.I. YIELD STRENGTH ASTM A-706 STEEL REINFORCING.
- COVER DESIGNED FOR PARKWAY LOADING 300 P.S.F. OR TRAFFIC LOADING H-20.
- PULL BOX TO BE PLACED ON A MIN 6" BASE OF CRUSHER RUN FOR EASE OF INSTALLATION AND EVEN LOAD DISTRIBUTION.

**ORDERING INFORMATION:**

PER CITY OF ANAHEIM SPECS. CU1600-3A.  
TOTAL WEIGHT OF ASSEMBLY IS 2,472 Lbs.

**PARKWAY ASSEMBLY WITH STEEL B/D COVER K3048-DP36-16P.**  
**LIGHT TRAFFIC ASSEMBLY WITH STEEL B/D COVER K3048-DP36-16L.**

1. PB3048-B30-05, 30" BOTTOM SECTION. WT. 2,015 lbs.
2. PB3048-16F, 6" TOP SECTION. W/(F3048-PB-ANG) GALV. CAST IN ANGLE FRAME. WT. 331 Lbs.
- 3A. SC3048-PGVE, ONE PIECE PARKWAY COVER GALV., MARKED "ELECTRIC".
- 3B. SC3048-TGVE, ONE PIECE TRAFFIC COVER GALV., MARKED "ELECTRIC".
4. 6" x 7" DIA. SUMP x 3" DEEP. BOTTOM SECTION (1).
5. 14" x 14" DUCTED K.O. x 12" DEEP. LOCATE AS FOLLOWS: BOTTOM SECTION (2).
6. 8" x 16" K.O. x 3" DEEP. LOCATE AS FOLLOWS: BOTTOM SECTION (4).
7. 7/8" DIA. x 9" GALV. PULL IRON. BOTTOM SECTION (2).
8.  $\phi$  1" DIA. BLIND GROUND ROD HOLE. BOTTOM SECTION (2).
9.  $\pm$  1/2" PLASTIC INSERT. LOCATE AS FOLLOWS: BOTTOM SECTION (8).
10.  $\bullet$  1/2" P-35-T O.B. INSERT W/CLEAN-OUT HOLE. LOCATE AS FOLLOWS: TOP SECTION (6) FRAME MTD.

**GENERAL NOTES:**

1. Minimum soil bearing capacity is hereby assumed to be 2000 PSF unless otherwise documented by a geotechnical report that shall be provided to Jensen Precast by the end user. Jensen Precast shall not be held responsible for the soil bearing capacity.
2. Installation of Manholes, Vaults, Handholes, Meter Boxes etc. will be as per Jensen Installation procedures.
3. Structural modification to the Jensen line of products is not permitted without prior written approval from Jensen Engineering Department.
4. Do not scale the drawings, verify all dimensions including rough openings, if any discrepancies are found, notify the Jensen Engineer immediately.
5. The Jensen Engineer will interpret the intent of the drawings in case of possible conflict or discrepancy.
6. Permissible Variations:
  - Dimensional Tolerances – The length, width, height, or dia. measurements of the structure when measured on the inside surfaces shall not deviate from design dimensions by more than the following:
    - Dimensions: Tolerance:
      - 0 to 5 Feet 1/4"
      - 5 to 10 Feet 3/8"
      - 10 to 20 Feet as agreed upon between the supplier and purchaser.
  - Squareness Tolerance: The inside of the precast concrete component shall be square as determined by diagonal measurements. The difference between such measurements shall not exceed the following:
    - Measured Length: Allowable Difference
      - 0 to 10 Feet 1/2"
      - 10 to 20 Feet 3/4"
7. Between the supplier and purchaser.

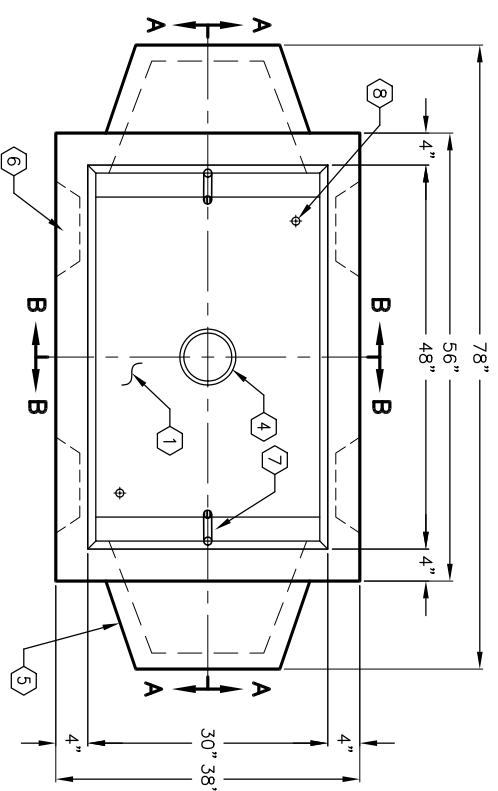
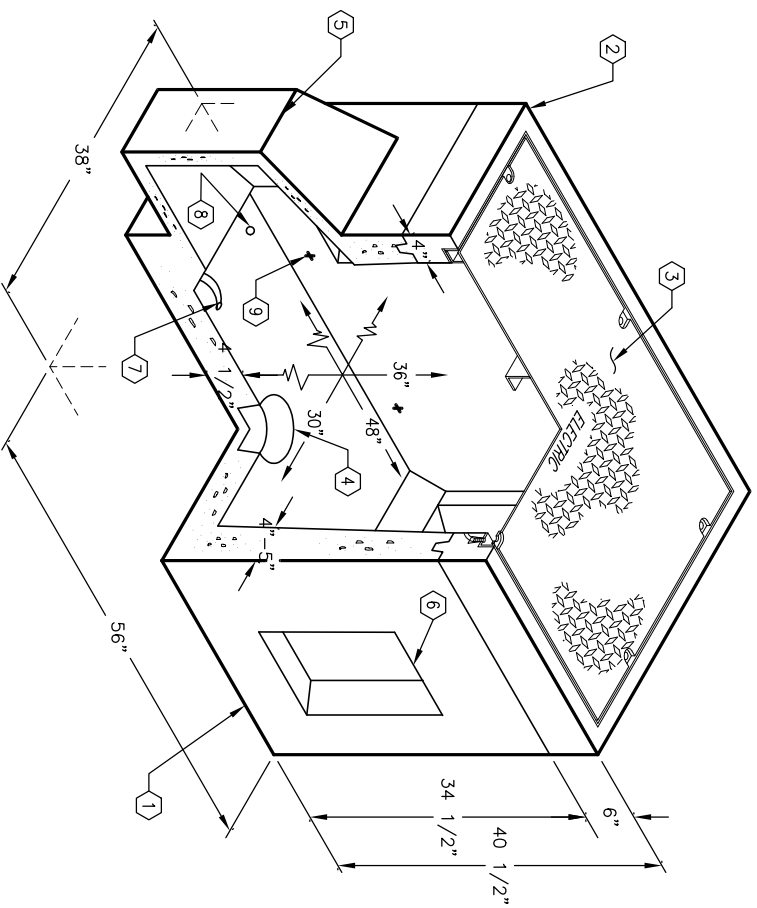

**PLAN VIEW**

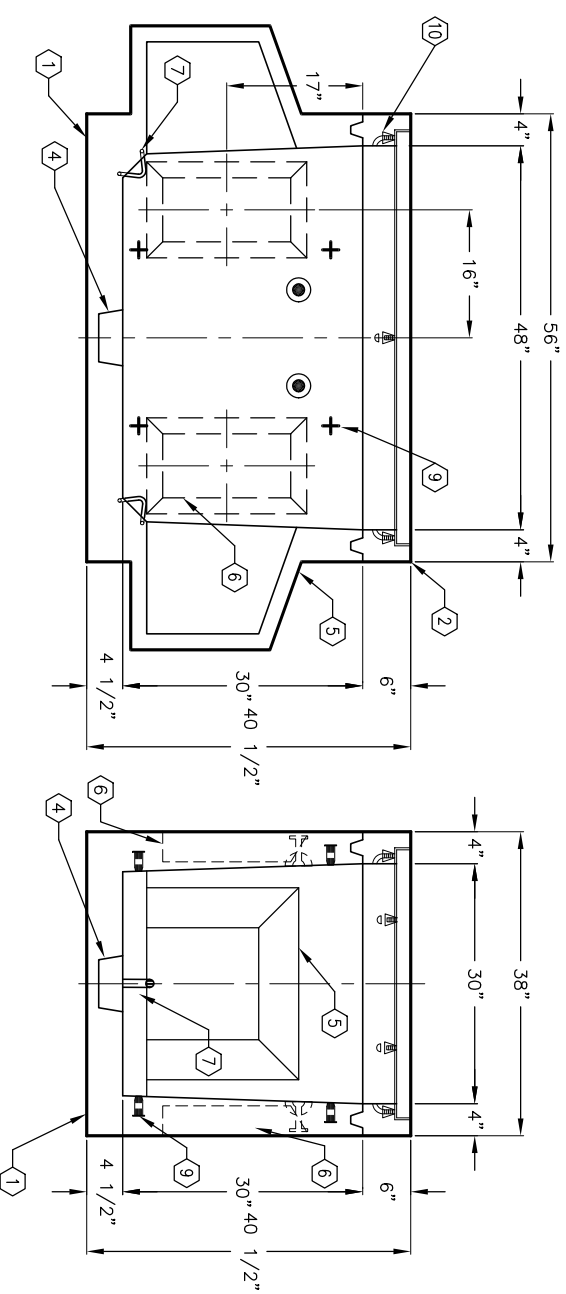

**SECTION A-A**

**SECTION B-B**



**K3048-DP36-16**  
PER ANAHEIM SPECS. 1600-3A



#	DATE	DESCRIPTION	BY

**K3048-DP36-16**  
PER ANAHEIM SPECS. 1600-3A