

35TA-I INTERCEPT PULLBOX

3'-0"x5'-0"x3'-0"
(NOMINAL INSIDE DIMENSIONS)

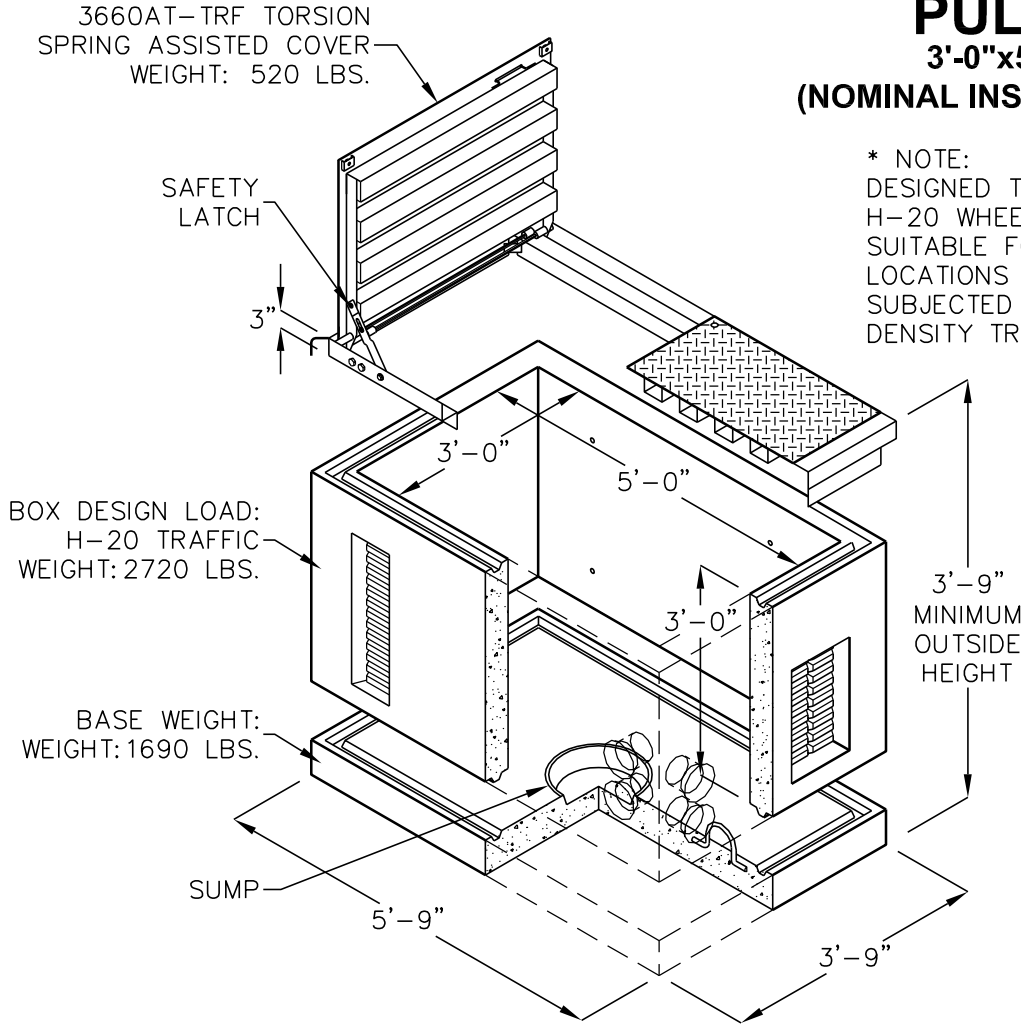

* NOTE:
DESIGNED TO WITHSTAND
H-20 WHEEL LOADINGS,
SUITABLE FOR OFF-STREET
LOCATIONS WHERE NOT
SUBJECTED TO HIGH
DENSITY TRAFFIC.

OPTIONAL RISERS (EXTENSIONS)		
MODEL NO.	B	WEIGHT
35-R6	6"	420 LBS.
35-R12	12"	840 LBS.

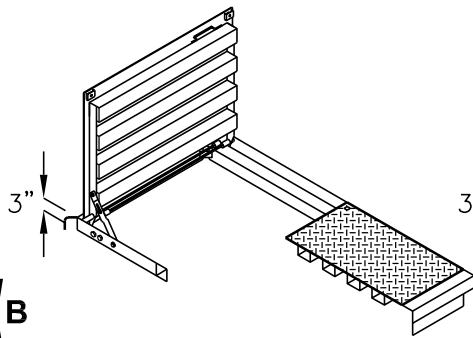
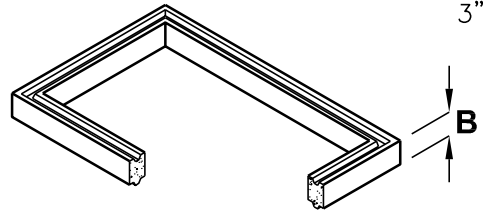

ADJUSTABLE TORSION SPRING ASSISTED COVERS (DIAMOND PLATE SURFACE)

* 3660AT-TRF, 520 LBS. (H-20 TRAFFIC)
OR
3660AT-PKY, 420 LBS. (NON-TRAFFIC)

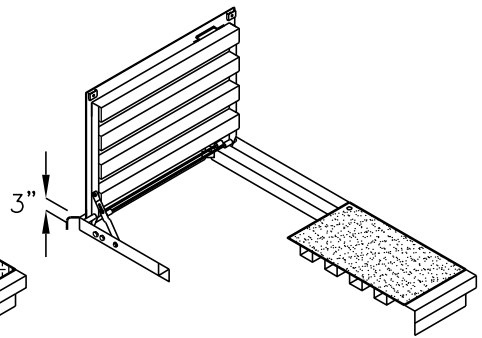

ADJUSTABLE TORSION SPRING ASSISTED COVERS (NON-SLIP SURFACE)

* 3660AT-TRF-AG, 510 LBS. (H-20 TRAFFIC)
OR
3660AT-PKY-AG, 410 LBS. (NON-TRAFFIC)

FOR COMPLETE DESIGN
AND PRODUCT INFORMATION
CONTACT JENSEN PRECAST.

Jensen Precast reserves the right to make changes to product design and/or dimensions without notice. Please contact Jensen Precast whenever necessary for confirmation or advice on product design.

