

2000 GALLON GREASE INTERCEPTOR

MODEL JP2000EPE-G
LISTED BY UPC®
NORTHERN CALIFORNIA

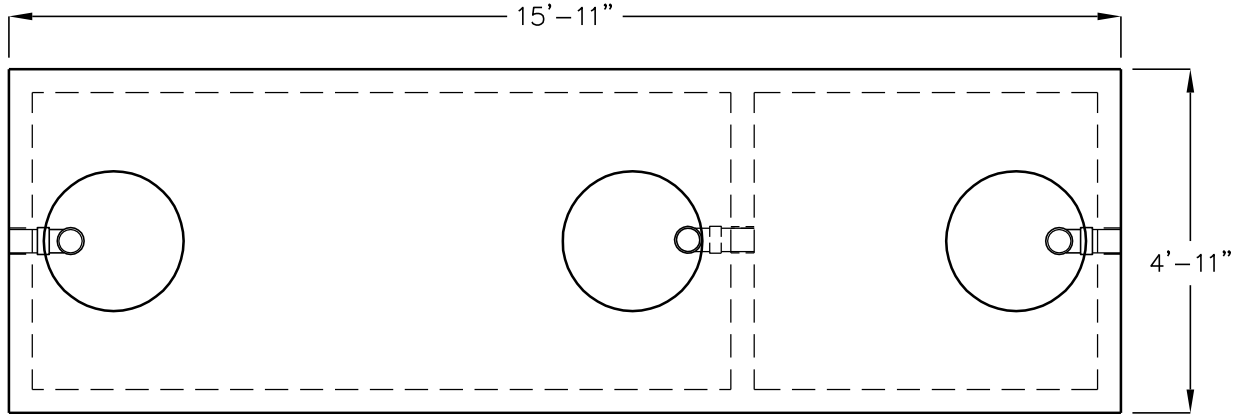

TOP VIEW
(COVERS AND RINGS REMOVED)

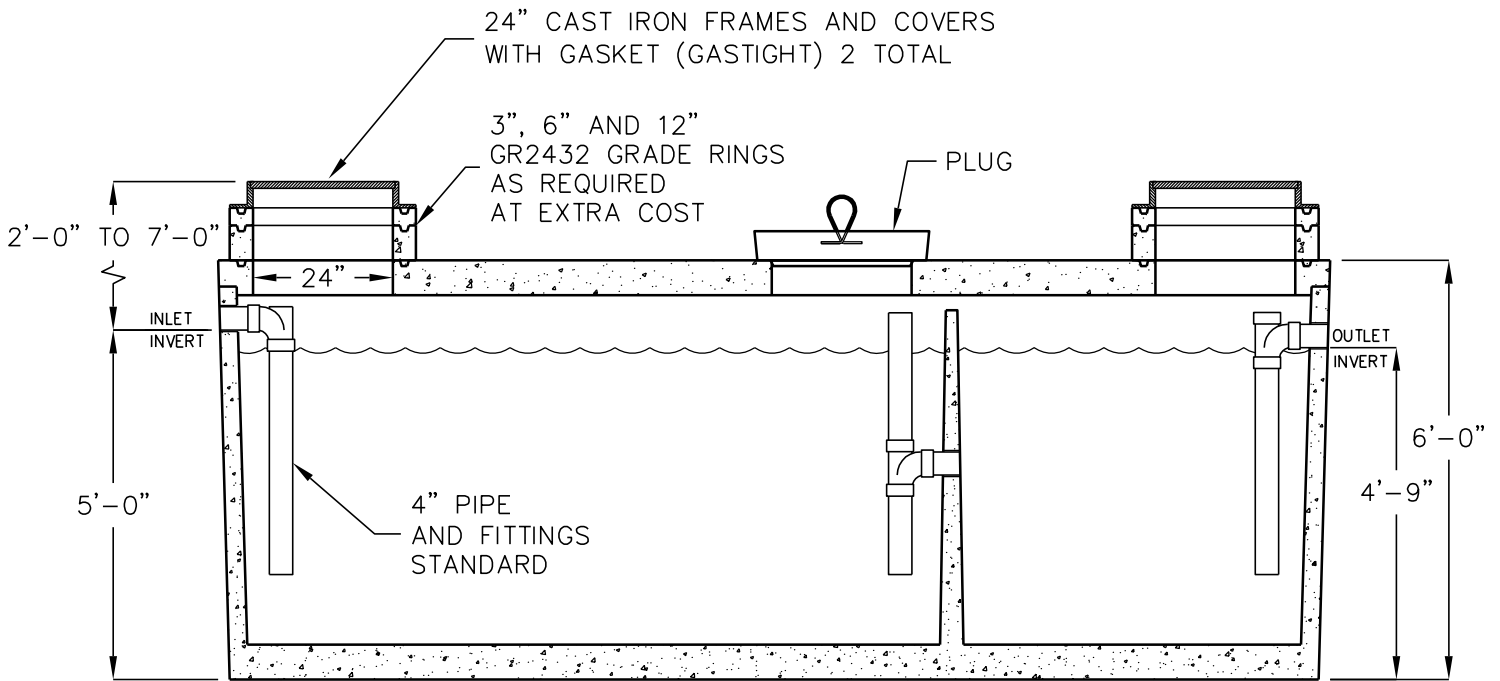

SIDE SECTION VIEW

OPERATING CAPACITY: 2,000 GALLONS.

DESIGN LOAD: H-20 TRAFFIC WITH DRY SOIL CONDITIONS
(WATER LEVEL BELOW TANK) AND 1'-6' EARTH COVER.

SUITABLE SUB-BASE BEDDED WITH GRANULAR MATERIAL SHALL BE
PREPARED TO HANDLE ANTICIPATED LOADS.

FOR COMPLETE DESIGN AND PRODUCT INFORMATION
CONTACT JENSEN PRECAST.

MINIMUM EXCAVATION
5'-11" x 16'-11"
x REQ'D DEPTH