

# 2'-6" x 4'-0" ANAHEIM DUCTED INTERCEPT BOX x 36" DEEP

**NOTES:**

- INTERCEPT BOX DESIGNED IN ACCORDANCE WITH AASHTO H-20-44 TRAFFIC BRIDGE LOADING USING 5,500 PSF COMPRESSIVE STRENGTH CONCRETE AND 60,000 PSI YIELD STRENGTH ASTM A-706 STEEL REINFORCEMENT.

- COVER DESIGNED IN ACCORDANCE WITH AASHTO PARKWAY LOADING 300 psf. OR TRAFFIC H-20.
- INTERCEPT BOX TO BE PLACED ON A MIN. 6" BASE OF CRUSHER RUN FOR EASE OF INSTALLATION AND END LOAD DISTRIBUTION.

1. PB3048-B-05, BASE SLAB, WT. 1,700 Lbs.
2. PB3048D-I27-05, INTERMEDIATE SECTION, WT. 1,223 Lbs.
3. PB3048-16F, TOP SECTION W/(F3048-PB-ANG) GALV. ANGLE FRAME CAST IN WT. 213 Lbs.
- 4A. SC3048-PGVE, ONE PIECE PARKWAY COVER GALV., MARKED "ELECTRIC".
- 4B. SC3048-TGVE, ONE PIECE TRAFFIC COVER GALV., MARKED "ELECTRIC".
5. 6" x 7" DIA. SUMP x 2" DEEP BASE SLAB (1).
6. 14" x 14" DUCTED K.O. x 12" DEEP INTER. SECTION (2).
7. 8" x 16" K.O. x 3" DEEP INTER. SECTION (4).
8. 7/8" x 9" PULL IRON. LOCATE AS FOLLOWS: BASE SLAB (2)
9. @ 1/2" P-35-T INSERTS. LOCATE AS FOLLOWS: INT. SECTION (12).
10. @ 1/2" P-35-T INSERTS W/CLEAN-OUT HOLES. LOCATE AS FOLLOWS: TOP SECTION (6) FRAME MTD.

**ORDERING INFORMATION:**

PER CITY OF ANAHEIM SPECS. CU1600-3A.  
TOTAL WEIGHT OF ASSEMBLY SHOWN IS 3,406#.

**PARKWAY ASSEMBLY WITH STEEL B/D COVER K3048-DI36-16P.**  
**LIGHT TRAFFIC ASSEMBLY WITH STEEL B/D COVER K3048-DI36-16T.**

**GENERAL NOTES:**

1. Minimum soil bearing capacity is hereby assumed to be 2000 PSF unless otherwise documented by a geotechnical report that shall be provided to Jensen Precast by the end user. Jensen Precast shall not be held responsible for the soil bearing capacity.
2. Installation of Manholes, Vaults, Handholes, Meter Boxes etc. will be as per Jensen installation procedures.
3. Structural modification to the Jensen line of products is not permitted without prior written approval from Jensen Engineering Department.
4. Do not scale the drawings, verify all dimensions including rough openings, if any discrepancies are found, notify the Jensen Engineer immediately.
5. The Jensen Engineer will interpret the intent of the drawings in case of possible conflict or discrepancy.
6. Permissible Variations:  
Dimensional Tolerances – The length, width, height, or dia. measurements of the structure when measured on the inside surfaces shall not deviate from design dimensions by more than the following:  
Dimensions: Tolerance:  
0 to 5 Feet 1/4"  
5 to 10 Feet 3/8"  
10 to 20 Feet as agreed upon between the supplier and purchaser.  
Squariness Tolerance:  
The inside of the precast concrete component shall be square as determined by diagonal measurements. The difference between such measurements shall not exceed the following:  
Measured Length: Allowable Difference  
0 to 10 Feet 1/2"  
10 to 20 Feet 3/4"  
20 Feet and over as agreed upon between the supplier and purchaser.
- 7.

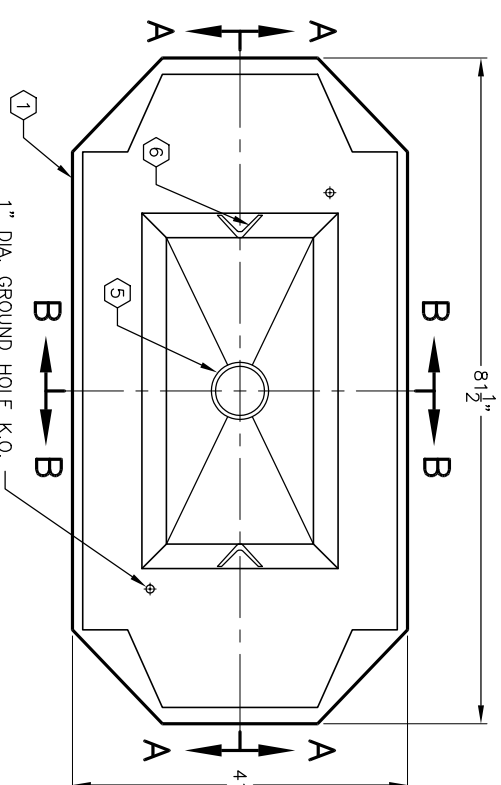
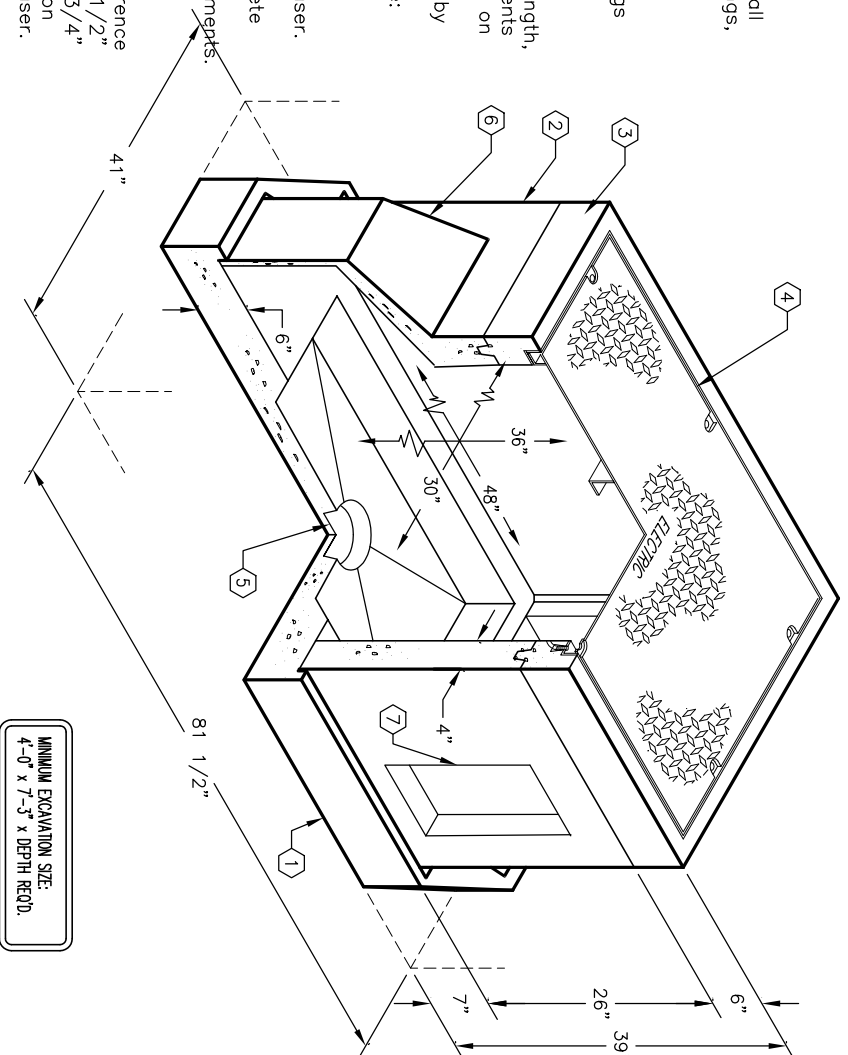

**PLAN VIEW OF BOTTOM SLAB**

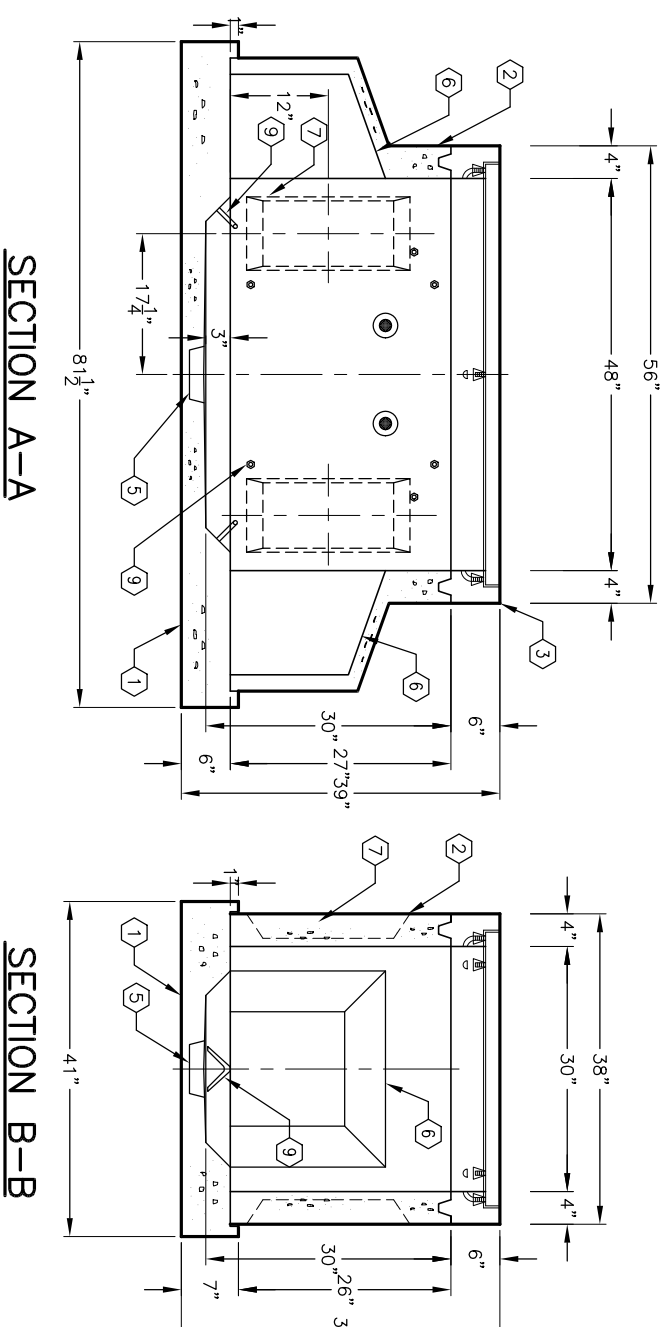

**SECTION A-A**

**SECTION B-B**

**JENSEN**  
PRECAST

AUTOCAD REL. 14

**K3048-DI36-16**

PER ANAHEIM SPECS. 1600-3A

03-01-02

**JENSEN**  
PRECAST

#	DATE	DESCRIPTION	BY

**K3048-DI36-16**

PER ANAHEIM SPECS. 1600-3A

03-01-02