

4'-0" x 6'-6" IID PARKWAY MEDIUM MANHOLE x 7'-0" DEEP

NOTES:

- CONCRETE IS DESIGNED FOR H-20-44 TRAFFIC LOADING USING 5,500 PSI [37.92MPa] COMPRESSIVE STRENGTH CONCRETE AND 60,000 PSI [413.2MPa] YIELD STRENGTH ASTM A-706 STEEL REINFORCEMENT PER CALCS. #31725.
 - POLYMER CONCRETE COVER DESIGNED FOR PARKWAY LOADING: 500 PSF.
 - HANDHOLE TO BE PLACED ON A 6" BASE OF CRUSHER RUN FOR EASE OF INSTALLATION AND EVEN LOAD DISTRIBUTION.
 - 7/8" X 1 3/4" CONSEAL GASKET (45 FT. REQ'D) WILL BE SHIPPED WITH EACH HANDHOLE.
1. PB466-B60-25, 60" BTM SECTION (CG-466-B60-25), WT.11,650 lbs. PB466-112-25, 12" TOP SECTION (CG-466-112-25) GALV. ANGLE FRAME CAST-IN, (F466-PB-RPM) WT. 1,750 lbs.
 2. PB466-R12, 12" GRADE RING (CG-466-R12), WT. 1,750 lbs. PB466-R24, 24" EXTENSION SECTION (R466-R24), WT. 3,450 lbs. (NOT SHOWN, AVAILABLE ON SPECIAL ORDER.)
 3. 3-PIECE POLYMER CONCRETE W/(12) 1/2"-13NC x 2 1/2" S.S.P.H. BOLTS FOR BOLT DOWN, & MARKED "I.I.D." 369 lbs.
 4. 1" DIA. GROUND ROD KNOCK OUT. LOCATE AS FOLLOWS: BOTTOM SECTION (2) CORE MTD.
 5. 12" x 13" DIA. SWMP x 4" DEEP (5000-356). LOCATE AS FOLLOWS: BOTTOM SECTION (1) CORE MTD.
 6. 5" CONTERM (5563G). LOCATE AS FOLLOWS: BOTTOM SECTION (16) CORE MTD.
 7. 1/2" DIA. BRONZE GROUND INSERT WELDED TO REIN. W/PLASTIC PLUG. MARKED "GRD" IN RED. BOTTOM SECTION (2) CORE MTD.
 8. 7/8" x 4 1/2" PULL IRON W/LEGS. LOCATE AS FOLLOWS: BOTTOM SECTION (9) CORE MTD.

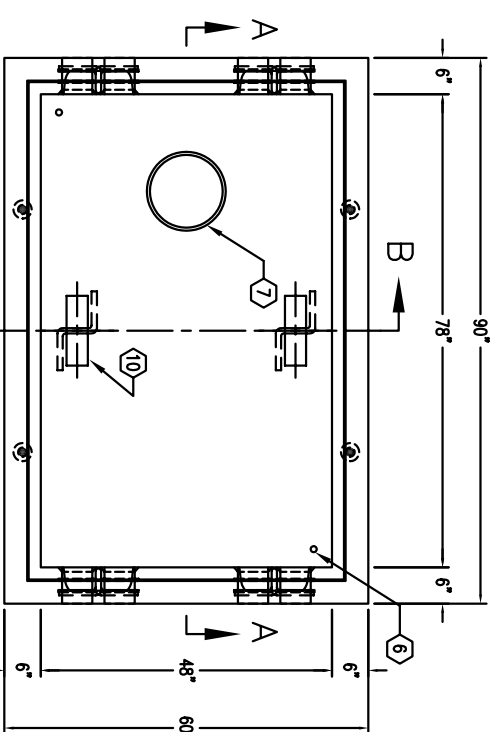

PLAN VIEW

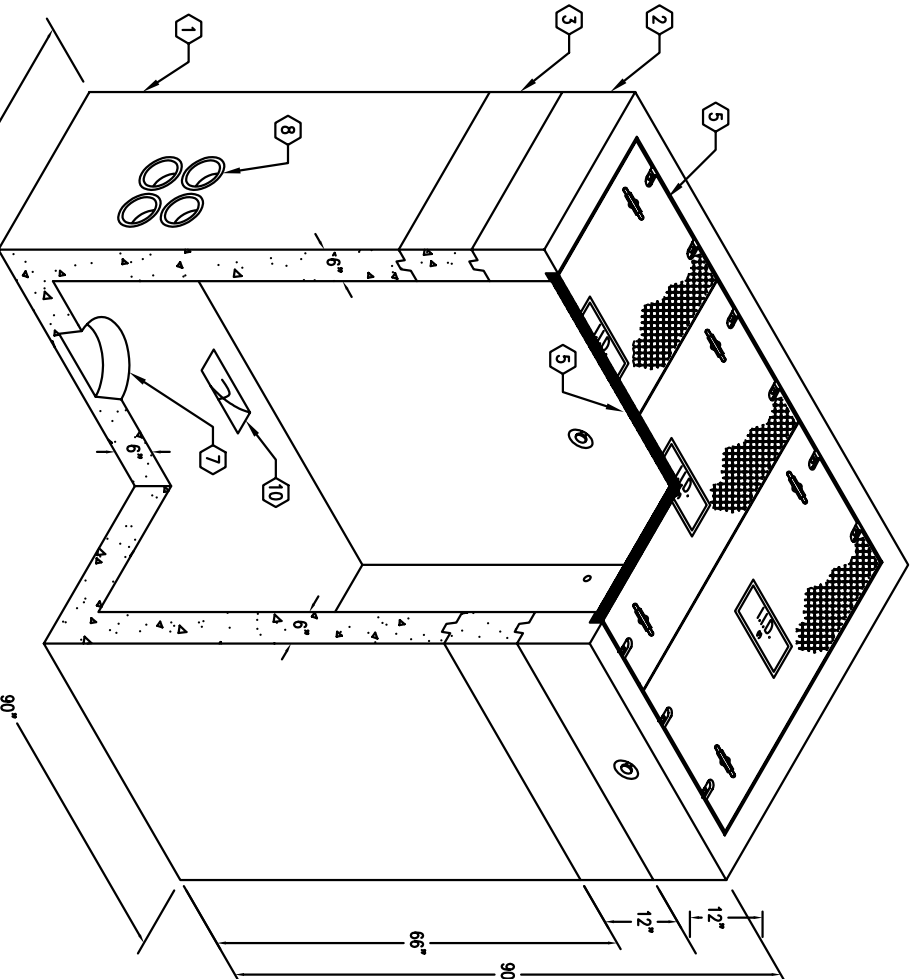

- GENERAL NOTES:**
1. Minimum soil bearing capacity is hereby assumed to be 2000 PSF unless otherwise documented by a geotechnical report that shall be provided to Jensen Precast by the end user. Jensen Precast shall not be held responsible for the soil bearing capacity.
 2. Installation of Manholes, Vaults, Handholes, Meter Boxes etc. will be as per Jensen Installation procedures.
 3. Structural modification to the Jensen line of products is not permitted without prior written approval from Jensen Engineering Department.
 4. Do not scale the drawings, verify all dimensions including rough openings, if any discrepancies are found, notify the Jensen Engineer immediately.
 5. The Jensen Engineer will interpret the intent of the drawings in case of possible conflict or discrepancy.
 6. Permissible Variations:
 - Dimensional Tolerances – The length, width, height, or dia. measurements of the structure when measured on the inside surfaces shall not deviate from design dimensions by more than the following:

Dimensions:	Tolerance:
0 to 5 Feet	1/4"
5 to 10 Feet	3/8"
10 to 20 Feet as agreed upon between the supplier and purchaser.	3/8"
 - Squareness Tolerance: The inside of the precast concrete component shall be square as determined by diagonal measurements. The difference between such measurements shall not exceed the following:

Measured Length:	Allowable Difference
0 to 10 Feet	1/2"
10 to 20 Feet	3/4"
 7. 20 Feet and over as agreed upon between the supplier and purchaser.

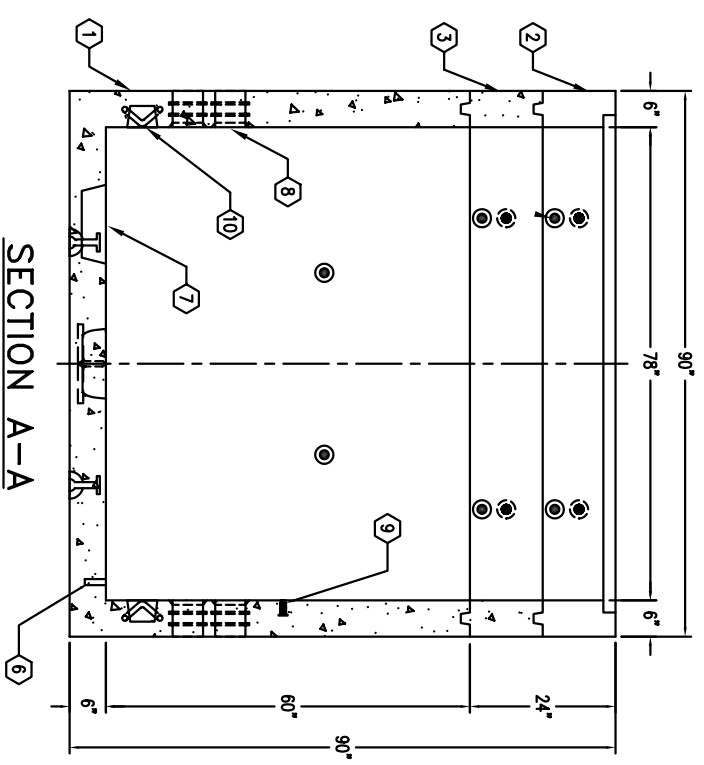

SECTION A-A

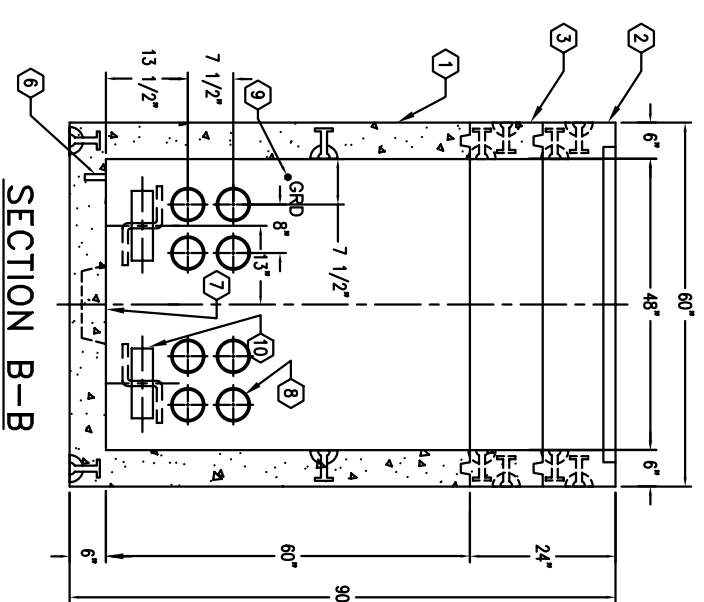

SECTION B-B



AMPOD REL. 14

MINIMUM EXCAVATION SIZE:
6'-0" x 8'-0" x DEPTH REQ'D.

K466-FH84-25P

PER ILL. 555 Rev.01 11-9-00

05-03-04



#	DATE	DESCRIPTION	BY

K466-FH84-25P

PER ILL. 555 Rev.01 11-9-00

05-03-04