

COVER ADJUSTMENT DETAIL

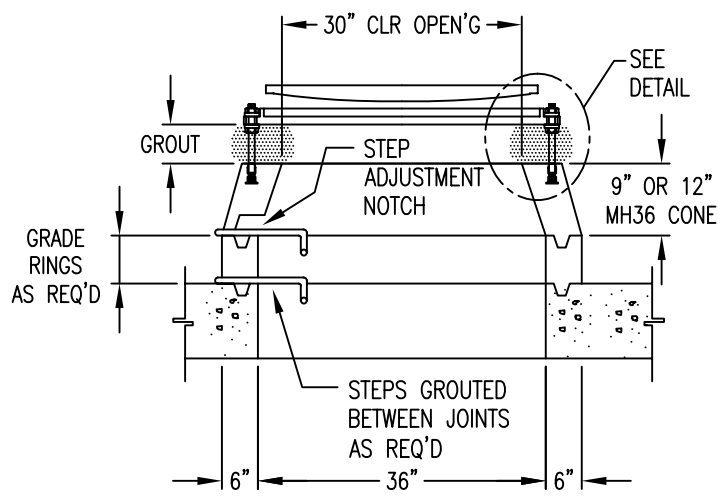

CROSS SECTION

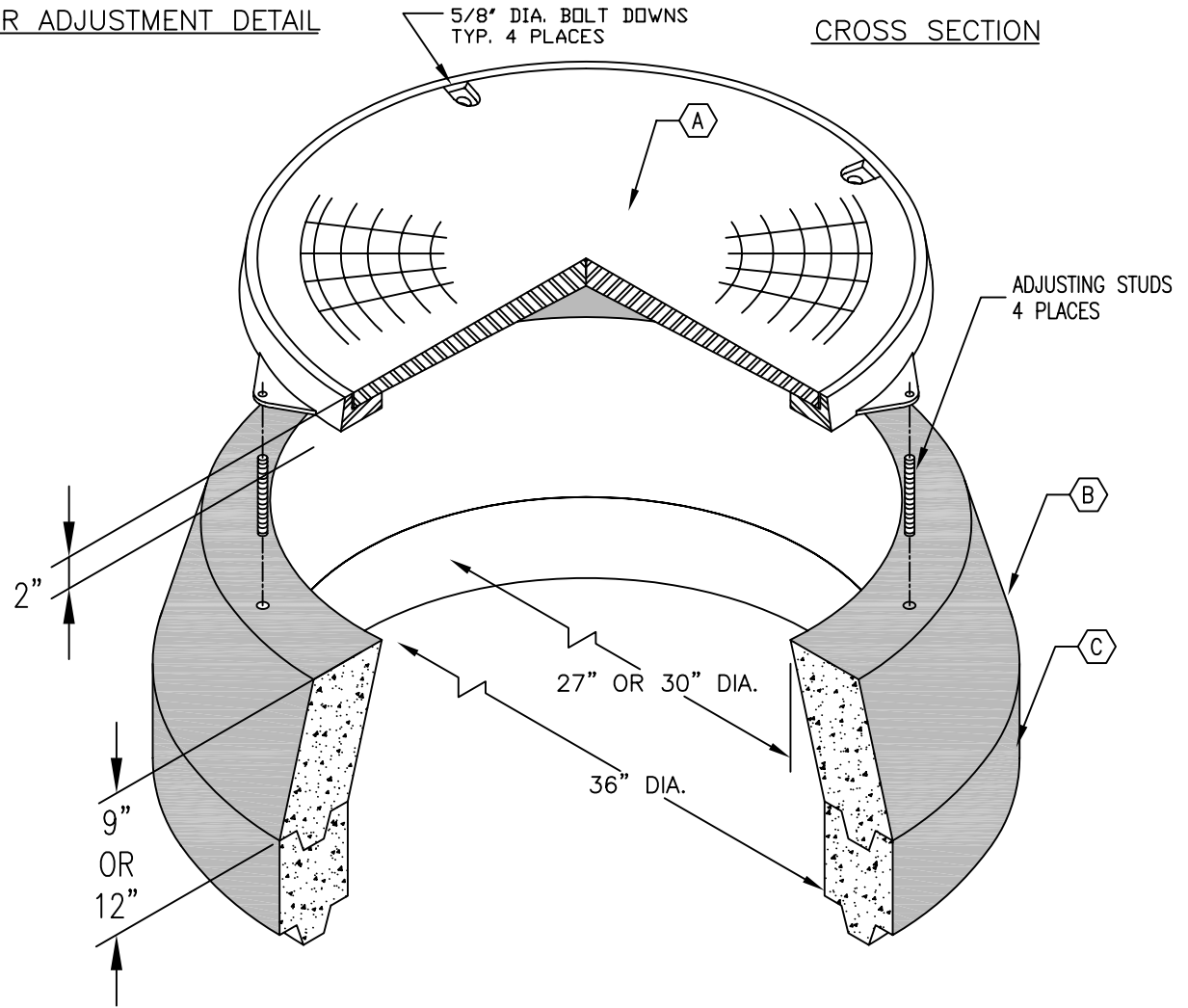

- Ⓐ 27" OR 30" DIA. CAST IRON COVER & FRAME.
- Ⓑ CONCRETE NECKING SECTION 9" OR 12" TALL.
- Ⓒ 3", 6", OR 12" EXTENSION RINGS.

- CONCRETE DESIGNED FOR H-20-44 BRIDGE LOADING.
- ILLUSTRATION IS TYPICAL ONLY OF GENERAL SERIES CONFIGURATION: FOR SPECIFIC CONFIGURATION, CALL JENSEN PRECAST.

NOTE

IT IS THE RESPONSIBILITY OF THE SPECIFICATION AUTHORITY, END USER, CONTRACTOR, ETC. TO CAREFULLY CONSIDER EACH LOCATION AND TO DETERMINE IF BOLTS SHOULD BE INSTALLED BEFORE THE LOCATION IS SUBJECTED TO PUBLIC USE EITHER AS AN IN-CONSTRUCTION, TEMPORARY, PHASE INSTALLATION OR A FINAL INSTALLATION.

27" OR 30" DIA. CAST IRON MANHOLE & NECKING FOR POWER		
MN36 SERIES POWER		
ORG. DWG. DATE 12-15-00	REV. DWG. DATE 06-07-01	