

612-12 TELEPHONE MANHOLE

6'-0"x12'-0"x12'-0"
(NOMINAL INSIDE DIMENSIONS)

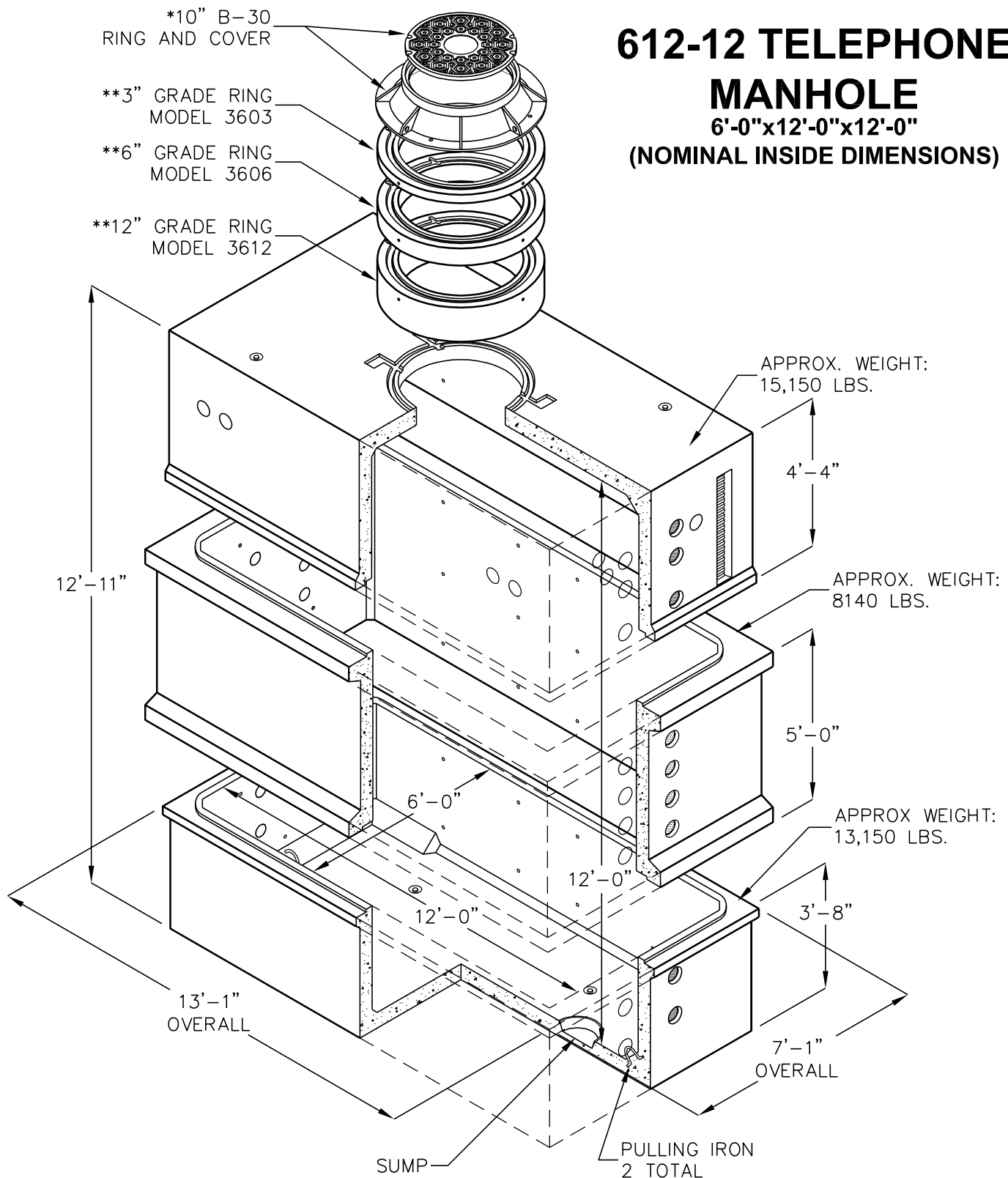

* SEE HARDWARE/APPURTENANCES SECTION FOR SPECIFICATIONS.
 **RISERS OPTIONAL. SEE COLLAR/RISER SECTION FOR SPECIFICATIONS.

BOX DESIGN LOAD: H-20 TRAFFIC WITH 1' TO 5' SOIL COVER.

FOR COMPLETE DESIGN AND PRODUCT INFORMATION
 CONTACT JENSEN PRECAST.

Jensen Precast reserves the right to make changes to product design
 and/or dimensions without notice. Please contact Jensen Precast whenever
 necessary for confirmation or advice on product design.