

750 GALLON CLARIFIER

MODEL JP750-ECE-CL
TRAFFIC RATED

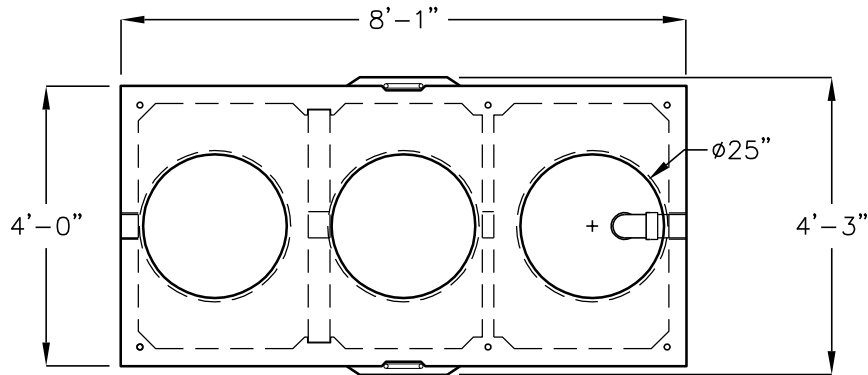

PLAN VIEW

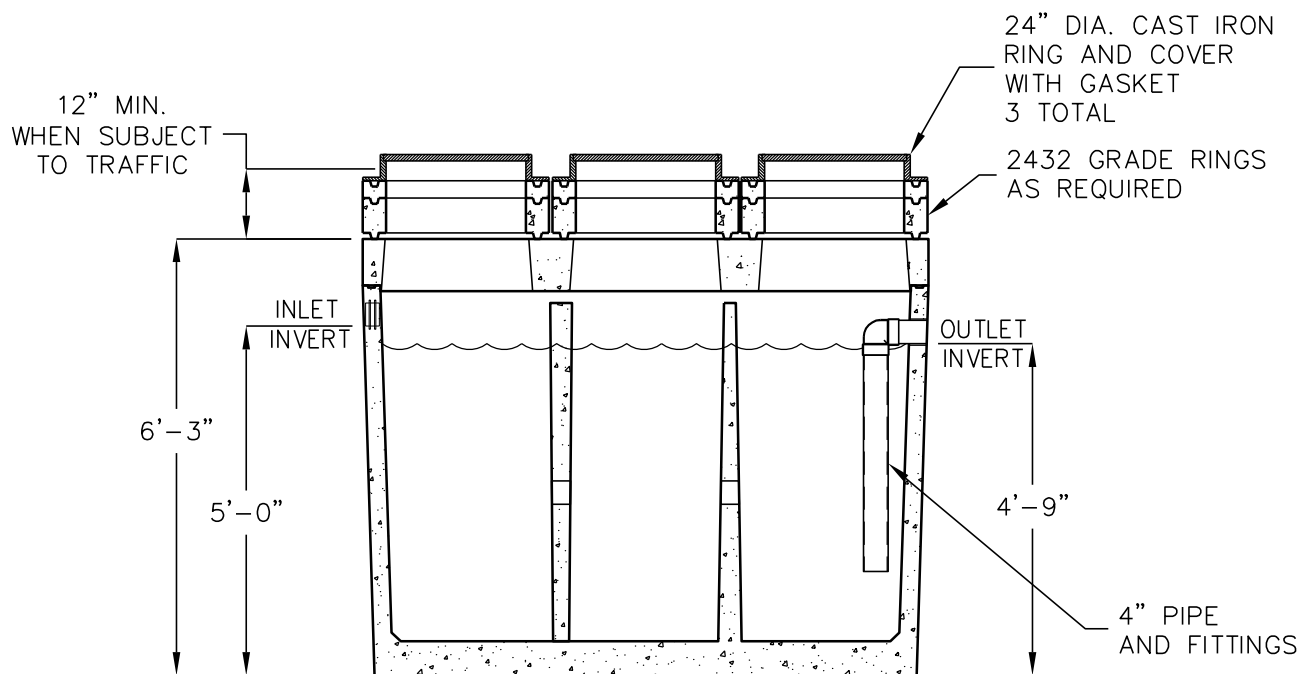

ELEVATION SECTION

OPERATING CAPACITY: 750 GALLONS.

DESIGN LOAD: H-20 TRAFFIC WITH DRY SOIL CONDITIONS (WATER LEVEL BELOW TANK) AND 1 TO 6 FEET EARTH COVER.

SUITABLE SUB-BASE BEDDED WITH GRANULAR MATERIAL SHALL BE PREPARED TO HANDLE ANTICIPATED LOADS.

FOR COMPLETE DESIGN AND PRODUCT INFORMATION CONTACT JENSEN PRECAST.

MINIMUM EXCAVATION 5'-0" x 9'-1" x REQ'D DEPTH
--

Jensen Precast reserves the right to make changes to product design and/or dimensions without notice. Please contact Jensen Precast whenever necessary for confirmation or advice on product design.

